

IWAKI
AIR
PUMPS

APN-W



Air pumps which can pump both gas &

The APN-W series are gas-liquid transfer pumps. The use of a special diaphragm allows the pump to transfer both air and liquid. The miniaturized & lightened body offers optimum sizing for various equipment such as analyzers, in which compactness is always a key requirement.



APN-05, 10, 20-W
(DC motor type)



APN-30, 60-W
(Brushless DC motor type)



APN-30, 60-W
(DC motor type)



APN-085-W
(AC motor type)



APN-085-W
(DC motor type)

Construction and materials

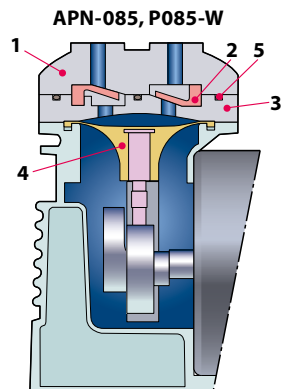
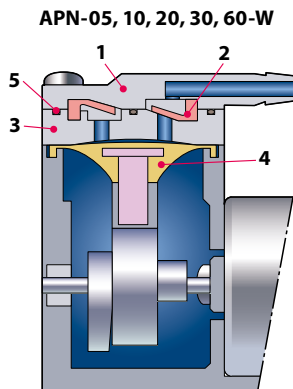

Model	APN - 05, 10, 20, 30, 60 - W	APN-085-W, P085 - W	
		E	V
1 Pump head	GFRPP	GFRPP	GFRPP
2 Valve	FKM, EPDM, Perfluoro ^{Note}	EPDM	FKM
3 Valve seat	GFRPP	GFRPP	GFRPP
4 Diaphragm	FKM, EPDM, PTFE/EPDM ^{Note}	EPDM	FKM
5 Gasket	FKM, EPDM, Perfluoro ^{Note}	EPDM	FKM

Note: Special order on APN-05,10 & 20.

Pump identification

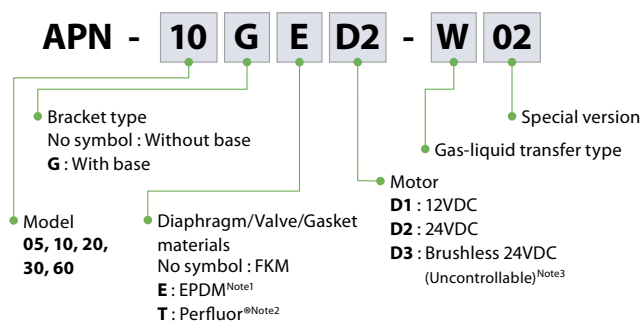

Note1: Model 10/20/30/60 only
Note2: Model 10/20 only
Note3: Model 30/60 only

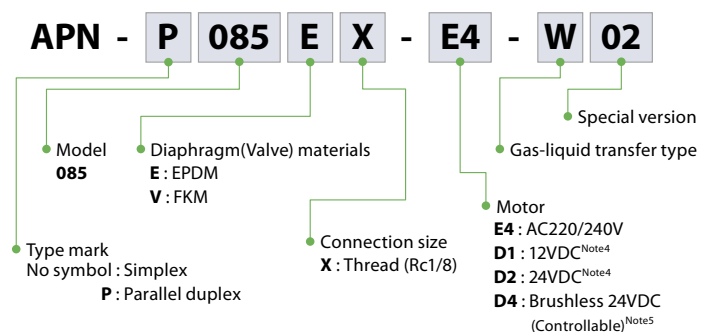

Note4: Special order
Note5: Simplex type only

liquid

- Design for transferring both gas and liquid ensures long life.
- Ideal for waste liquid collection thanks to the ability to handle entrained gas.
- Ultra-compact and lightweight.
- Capable of self-priming under dry condition.
- High corrosion resistance.
- Low noise and Oil-free design.



Specifications

Model	Gas			Gas-liquid	Connection size IN/OUT	Motor				Mass (kg)
	Max. flow (L/min)	Max. discharge pressure (MPa)	Max. vacuum (kPa)	Max. capacity (L/min)		Output (W)	Power consumption (W)	Rated current (A)	Rated voltage (V)	
APN-05-W	0.1	0.01	87.99	0.05	Hose 4.5mm dia.	2.5	4.8	0.2 ^{Note3}	DC24	0.11
APN-10-W	0.2	0.03	74.66	0.1						
APN-20-W				0.2	Hose 5mm dia.					
APN-30-W	1.2 (1.0)	0.08	47.99	0.3		Hose 5.5mm dia.	5.8 (8)	11.5 (14.4)	0.48 ^{Note4} (0.6)	
APN-60-W				0.6						
APN-085E-W	3	0.05	34.66	0.5	Thread Rc1/8	20	48	0.22	AC220,240 (50Hz)	2.5
APN-085V-W			37.33							
APN-P085E-W	5		34.66	1.0			48			2.8
APN-P085V-W			37.33							
APN-085E-W	4	0.05	34.66	0.5	Thread Rc1/8	7.5	19.2	1.6	DC12	2.5
APN-085V-W			37.33							
APN-085E-W	4	0.05	34.66	0.5	Thread Rc1/8	20 (15)	19.2 (28)	0.8 (1.2)	DC24	2.5 (1.3)
APN-085V-W			37.33							

Note1: () is brushless 24VDC type

Note2: Brush type

Note3: 12VDC type is 0.4A

Note4: 12VDC type is 0.96A

•Discharge side pressure should be less than specification.

•Handling gas temp. APN-05,10,20,30,60-W : 5 to 40 °C APN-085,P085-W : 0 to 40 °C

•Handling liquid temp. APN-05,10,20,30,60-W : 10 to 40 °C APN-085,P085-W : 5 to 40 °C

Performance curves (gas^{note})

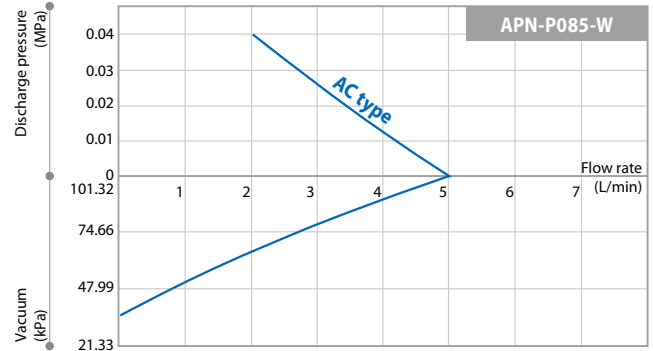
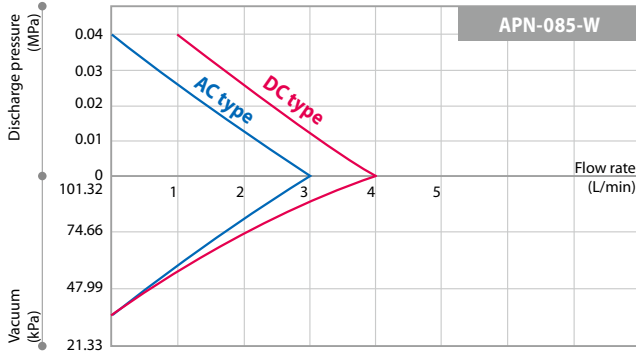
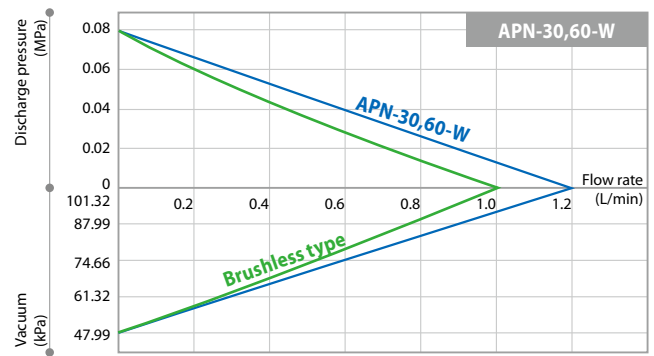
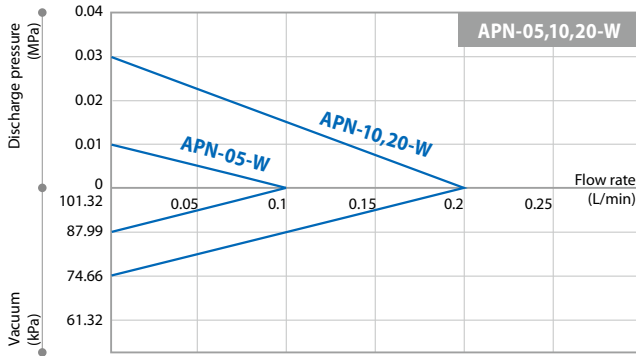

Note : Above performance shows when handling gas. When handling gas and liquid mixture, please contact us for pump performance.

Dimensions (in mm)

APN- 05, 10, 20, 30, 60 -W

APN-30,60-W Brush less type

Model	W	L	H	a	b	c	d
APN- 05,10-W	33	63	46	26	26	9	43.5
APN- 20 -W	33	63	46.4	26	26	9	44
APN- 30,60-W	40	80	55	30	30	12	52

APN-085-W

APN-P085-W

IWAKI CO., LTD. 6-6 Kanda-Sudacho 2-chome Chiyoda-ku Tokyo 101-8558 Japan
 TEL : (81)3 3254 2935 FAX : 3 3252 8892

() Country codes

IWAKI has global net work. Please find your distributor location at

www.iwakupumps.jp

European office : **IWAKI Europe GmbH**
 Germany : **IWAKI Europe GmbH**
 Holland : **IWAKI Europe GmbH** (Netherlands Branch)
 Italy : **IWAKI Europe GmbH** (Italy Branch)
 Spain : **IWAKI Europe GmbH** (Spain Branch)
 Belgium : **IWAKI Belgium N.V.**
 Denmark : **IWAKI Nordic A/S**
 Finland : **IWAKI Suomi Oy**
 France : **IWAKI France S.A.**
 Norway : **IWAKI Norge AS**
 Sweden : **IWAKI Sverige AB**
 U.K. : **IWAKI Pumps (UK) Ltd.**

TEL: (49)2154 9254 0 FAX: 2154 9254 48
 TEL: (49)2154 9254 50 FAX: 2154 9254 55
 TEL: (31)74 2420011 FAX: (49)2154 925448
 TEL: (39)0444 371115 FAX: 0444 335350
 TEL: (34)93 37 70 198 FAX: 93 47 40 991
 TEL: (32)13 67 02 00 FAX: 13 67 20 30
 TEL: (45)48 24 2345 FAX: 48 24 2346
 TEL: (358)9 2745810 FAX: 9 2742715
 TEL: (33)1 69 63 33 70 FAX: 1 64 49 92 73
 TEL: (47)23 38 49 00 FAX: 23 38 49 01
 TEL: (46)8 511 72900 FAX: 8 511 72922
 TEL: (44)1743 231363 FAX: 1743 366507

U.S.A. : **IWAKI America Inc.**
 Argentina : **IWAKI America Inc.** (Argentina Branch)
 Singapore : **IWAKI Singapore Pte Ltd.**
 Indonesia : **IWAKI Singapore** (Indonesia Branch)
 Malaysia : **IWAKI Sdn. Bhd.**
 Australia : **IWAKI Pumps Australia Pty Ltd.**
 Hong Kong : **IWAKI Pumps Co., Ltd.**
 China : **GFTZ IWAKI Engineering & Trading Co., Ltd.**
 : **IWAKI Pumps (Shanghai) Co., Ltd.**
 Korea : **IWAKI Korea Co., Ltd.**
 Taiwan : **IWAKI Pumps Taiwan Co., Ltd.**
 Thailand : **IWAKI (Thailand) Co., Ltd.**
 Vietnam : **IWAKI Pumps Vietnam Co., Ltd.**

TEL: (1)508 429 1440 FAX: 508 429 1386
 TEL: (54)11 4745 4116
 TEL: (65)6316 2028 FAX: 6316 3221
 TEL: (62)21 6906606 FAX: 21 6906612
 TEL: (60)3 7803 8807 FAX: 3 7803 4800
 TEL: (61)2 9899 2411 FAX: 2 9899 2421
 TEL: (852)2607 1168 FAX: 2607 1000
 TEL: (86)20 84350603 FAX: 20 84359181
 TEL: (86)21 6272 7502 FAX: 21 6272 6929
 TEL: (82)2 2630 4800 FAX: 2 2630 4801
 TEL: (886)2 8227 6900 FAX: 2 8227 6818
 TEL: (66)2 322 2471 FAX: 2 322 2477
 TEL: (84)613 933456 FAX: 613 933399

Caution for safety use:
 Before use of pump, read instruction manual carefully to use the product correctly.

Actual pumps may differ from the photos.
 Specifications and dimensions are subject to change without prior notice.
 For further details please contact us.

Legal attention related to export. Our products and/or parts of products fall in the category of goods contained in control list of international regime for export control. Please be reminded that export license could be required when products are exported due to export control regulations of countries.



The posting and copying from this catalogue without permission is not accepted firmly.