

IWAKI PUMPS

YfdUX`c`g`Y`Y_hfca U[bYh]W_ a ``

dc\ cbYa `≠K 5 ? ≡a cXY`A X(MX-250~403)

Bzj cX`_`cVg`i nY` fYj ropg f`j nXzbj

△ Û^:}æ c^Á^ÁÁđ q Á | ç [á^ { Á ð ^ Á ^ 0 Á æ } ^ c Á ç | [à \ Á [~ 0 ç æ Á

F mvlgo g"X^ao 'l'c'x d t" gtr cf m'u'grgmtqo agneticm o 'r qj qpgo "KY CMK^o qf gnMX.
 Vgpvq'p^a xqf 'm'iqdunw' g'unqw'f'm' clk-v p'ur t^a xp² 'c'dg' r g p² "o cpl^r wceg'u" gtr cf rgo .
 Ug' pco v'ug'"f mcf p 'u'v'p vq'p^a xqf go 'f 'k'g'p'gfl'r kvqwr 'g'm'iqdunw' g" gtr cf m.
 X pwl'g' xñ -p'f'r q' qtpquv'"Dg' r g pquv'p 'r qm'p o 'm' co gl gp'f'Àlo { 'pc'f t'cx'f'quqd".
 xctqxp o 'c'dwm'f o '\$Xctqx^a p'f'c'"Rq' qt" wx^a f p ej 'x'v'qo vq'p^a xqf w'
 Tgpvq'p^a xqf 'm'iqdunw' g'c'Àf t'fd 'o wu'f'xrcuypk/x-kej pk'h'qpg p'f'w'f'k'c'v'g'f' 'u'v'p . 'fg'"r t'ceqxp'f'm"
 qdunw'j { " gtr cf m'lg'l'o^a 'x'f'f' { 'r qj qvqx 'm'f'kur q' l'ek'h'r 'f' cf p² o w't { ej r² o w'pcj r² f p'w'f'o



CVgU

6 YndY bcgh	1-5
Nz_`UXb;]bZcfa UW'c'j fcV_i	6-12
1. X^ àæ } ðá [} d[æ	7
2. PrincipÁ i &^Á^! æ æ	7
3. Q^ } cã æ } ðÁ5áÁ [á^`	8
4. V^&@ æ . Ágãb Á	9
5. Ü[: { i^	9
6. Ni : ç^ Á [{] [] ^ } c Áá [ç^á^ } ð	10
7. P æ } ðÁ [~ i • cãá } æ^ } ð	13
InstalaWY	14-22
1. Ö ð^Á^0Áæ } ^c^Á^! æ [Á [~ 0çæÈ	15
2. Instala&	17
3. P[d^ àð	19
4. Ò^ d [ð • çæá	22
OVgì \ U	23-27
1. W [: [i] } ðÁ @^á } Á à • @ È	24
2. P ð çæá çá à • @ Á	25
3. Oà • @ È	26
ì XfyVU	28-41
1. Þi ç [áÁ Á á • dæ [ç i] } ðÁ çæá	29
2. ~ á : 0àæá [} d [æÁ	32
3. Þi @æá } ðÁ ð Á	35
4. D^ { [] } a 0ÁÁ [] a 0Á	36



6 YndY b'cgh'

Dc_nbmi_`VYndY bf`Ugdfzj bf`a Ubjdi `UWg` YfdUX`Ya

- F 'xg'pgf' c pgv" gtr cf m'r qwf'kcv'ug' pco v'ug'f mcf p 'u'qducj go "'ner kqnf "'Dgl r g pquv".
 'b fl' co gl 'vg'pgj qf' a o . 'r q-nq' gp'' k' v' v '' c '' gp''0
- F qf tflw'g'c" k v'ug'r qm'p { 'wxgf gp o k'x'v'q'ner kqrg"'Dgl r g pquv'. \ f g'wxgf gp²'r qm'p { "
 uqwf''pc'qej tcpw'wfkxcvgn " gtr cf gnc'lkp ej "quqd"x k'pgdg' r g ''c"-mqf "pc"'o clgwm0
- X | pco 'xctqxp ej 'l pc gni
 P' a urgf w'p'e'f x 'xctqxp²' l pc m' 'ucpqx''tq' ucj 'pgdg' r g ''c"-mqf . 'mgt²' j tq' ''r k'
 pgf qf tflgp''dg' r g pquv'ej 'r qm'p 'pgdq'r k'pgurt' a xp² o 'r qwf'k' a p'' gtr cf m0

 JUfcjzb	NYXcXfyYb`a `VYndY bcglb` c`dc_nbmi "'JUfcjzb` \ fcn`bVYndY `j zyb`f\ c`Uy`ga fh`b`f\ c`•fUni "
 Dcnf	NYXcXfyYb`a `VYndY bcglb` c`dc_nbmi` "Dcnf" \ fcn`bVYndY `•fUni `cgcV`Uy`cXmbU a U`h_i "

Xctqxpqw'p' a r n 'p' a urgf w'p'e'ej 'f xqw' l pc gni'pwpq'x'ff { 'f qf tflg0

	I j zX`fnU_znUb `•_cb` J'dcghi d"'I j b]h`_fi \ i ždcd " j b`_fi \ i `Y'nbzncfb b`_cb`f'fb`fnU_znUb `•_cb"
	I j zX`•_cb` J'dcghi d`j m'jUXi 'M'`M` c`VYnW nVbf dfcj YXYb` I j b]h`_fi \ i `Y'ncVfUhYbU`_cb`f'fb`]bbcglž _h'fz`a i g'fV hgd`b bU"

'6 YndY'ncgh

! J Ufcj z b t

• Dcý_cnYbf'bzglfc'Y'gci 'jYa 'j'byVYndY bf. Ú[~ 0c~w^Á[~ ^Áçæð Á æ~ @ç ~ bçÁ, d[b^Á, æð



Dcnf

• Dci yj z b t c g c V b t W 'cW f U b b W 'd f U W j b t W 'd f c g h Y X _ :] æ^ { [] a 0 æ [] a 0 æ [] [ç i á } ð ý á i 0 à ^ Á ^ à [Á æ æ ð ~ | æ æ Á ^ à ^ :] ^ { Á i ~ @ { Á æ æ ð ^ Á æ \ ç ^ Á ^ : } i { { æ | æ ç [~ d æ ~ ^ Á [~ 0 c æ Á | æ [ç] Á \ æ æ Á æ @ [~ Á æ | æ [ç] Á [ç É Ö i | ^] æ æ ð ~ | æ æ Á æ Á [\ | . Á i • ç Á 0 à ^ Á [~ 0 c ~ w ^ Á & @ æ] . Á i | Á æ æ \ Á æ Á



Dci yj Ync
..... CCDD

• NUa YnhY'ga fhY'bfa i 'fUni ' 'jdcfUb bfcgcV'j'X g'YX_i 'dzXi 'YfdUX'U'Z\ [] d [] w } ^ [] i ^ z ^ [] • É i @ á } . Á ^ i ^ z ^ } ð [] É á [] b } ð æ æ ^ à [Á ^ c : ~ Á [~ 0 c æ] . @ Á ^ : ç ^ á i } Á ^ i } æ | æ @ { Á • ç æ Á É \ [] d [] w Á i • ç æ } [~ Á ^ ç] [• ç æ æ Á ^ c : ~ Á [] [~ 0 æ . @ Á ^ Á ç ^ á } ^ Á ^ i } æ | æ : @ ^ á { Á Á @ [ç [• ç Á ^ i } æ | æ



Dcnf

• D 'nj YXz b t YfdUX'U'dca cW'UbUbyVc' Yh ni : \ [] d [] w Á [~ 0 æ Á á [ç æ æ @ : ç ^ á æ ç @ [] ~ à Á [] É i ~ @ É Á ^ Á ç ^ á i } Á ^ i } æ | æ Á æ i : i } [Á [~ 0 c æ Á] . Á ^ 0 Á \ Á { ~ Á i ^ } . Á ç ^ á æ Á [á É æ æ Á @ [: ð i á Á ^ i } æ | æ Á i • í á } Á i æ Á • [à É



Nz_Uh

• D Yfi yH'd t j c X Y ' YbYf [] Y j y X m d Y X ' n U z Y b t • X f y V m U ' j b W ' d f U W Z æ c ç ^ \ d æ . Á] ð æ ^ Á æ É æ Á ^ á [z [Á ^ á æ] Á Á i @ á } . { ~ Á ç ^ á ^ } Á [ç [: ~ Á { [• à æ æ @ { Á | æ Á æ Á ^ i } æ | Á Á @ } . { Á [• c á á ^ à [Á Á ç Á ^ Á] æ [~ Á ç æ } [• ç ^ ç ç Á • d æ] [~ Á } æ \ Á Á] ð æ ^ Á É } ^ * á Á [: [: ~ b ç Á " Ú Ú Ú Ó P 7 Á Ú Ú 7 Ó Ó " } Á ^ i } æ | É i @ á } { Á æ } ~ æ Á É æ i b } Á @ { Á ý á i 0 à : æ ð ^ } ð : } á i Á ^ á :] ^ ð ý : æ ^ Á • [à É



J m b h n X f c ^

• BYVYndY fnd gcVYbf'a Ugnetic_ a 'dc'Ya ' ^ i } æ | æ Á ^ \ d [{ æ } ^ { Á [@] ^ { Á à • æ @ Á } . Á ^ \ d [{ æ } ^ c Á { ç } ... ç Á i z ç [: á ^ Á ^ \ d [{ æ } ^ Á @ æ ð i | & É Á] . Á magnetic | Á [| Á [@ ~ } ^] ð } æ Á • [á á Á æ] [à Á [~ 0 c æ Á ^ \ d [] æ Á d [b É æ É á ^ } Á É



Dcnf

• D 'ja Ub]di 'UW'g'hcl]W_ a]'UnzdUW'cj a]'UdU]bUa] { ~ Á ç Á | æ [ç] Á i [• ç i á • ç } Á ç d i } É i | Á Á á • | @ [ç] æ [~ 0 c æ Á U U Ú (æ [Á æ É & @ æ] [~ Á æ \ , [& @ æ] . Á i | Á Á \ æ æ) .



Dcnf

6 YndY bcgh'

! J Ufcj z b ̣

• 8 f̣minid' UghW f\ c'a UYf]z' i '(g ̣ ̣ ẓ d ̣ f̣ i VUēnz `UXcj z' XYg U)

R'Áæ: i: | [Á & @] æ̣æ̣ ð' Á Á | æ̣æ̣ æ̣æ̣ .. @ Á æ̣æ̣ ã | ' Á @ { Á ç' á i } ð' Á i | æ̣æ̣ æ̣æ̣ Ṛ æ̣æ̣ Á @ [: ð : } ã ^ } ð' | æ̣æ̣ æ̣æ̣ & @ ð' Á Á | á Á i | æ̣æ̣ æ̣æ̣ Á i . ^ á } { Á [i æ̣æ̣ } ð' Á . [á Æ



• Nz_Uh' d YghUj Vm

Ú æ̣æ̣ | [ç i á } ð' Á ^ æ̣æ̣ ð' Á Á i | æ̣æ̣ æ̣æ̣ Á Á æ̣æ̣ ^ { Á @ [: ð' i 0) . Á [i æ̣æ̣ } ð' Á . [á Æ i æ̣æ̣ æ̣æ̣ lelel tricÉ \ { Á i [~ á ^ { Á Á [z [: ^ } ð' Á i | æ̣æ̣ æ̣æ̣ Á Á . } æ̣æ̣ Á Á Á Á ^ æ̣æ̣ ð' Á Á Á Á { Á Á á ^ :] ^ } . Æ



Nz_Uh' d f Uj

• 6 YndY bcghḅc̣dUh Yḅf̣d j' d Y Yfdzj z ḅf̣ḅVYndY b W ' UdU]b.

Ú æ̣æ̣ [~ 0 á Á i | æ̣æ̣ Á Á ^ } [~ Á Á Á ç' á ^ } & @ Á á ^ :] ^ } & @ æ̣æ̣ æ̣æ̣ Á ^ . ð' Á Á i | æ̣æ̣ æ̣æ̣ ç 0 á Á [] d [[ç æ̣æ̣ Á Á | á ç æ̣æ̣ Á Á Á Á | & @ : ^ [Á Á ^ c . } [. c { Á Á } á Á æ̣æ̣ & @ æ̣æ̣ æ̣æ̣ Æ Á Á Á Á ^ c . } & @ Á Á i | æ̣æ̣ Á Á } á æ̣æ̣ ð' Á æ̣æ̣ æ̣æ̣ æ̣æ̣ æ̣æ̣ Á @ [: ð' Á] . [á æ̣æ̣ [i æ̣æ̣ } ð' Á . [á a / ^ á] ç á ^ & @ [0 i] ð' Á ^ ç .

- P [| æ̣æ̣ . Á æ̣æ̣ æ̣æ̣ ^ Á
- S [i [:] æ̣æ̣ æ̣æ̣ . Á æ̣æ̣ æ̣æ̣ ^
- S æ̣æ̣ æ̣æ̣ ^ Á [á æ̣æ̣ . Á i [Á æ̣æ̣ . Á [Æ



Dietyl. æ̣æ̣ . • á [~ @ ð , peroxid ^ , ç á z } æ̣æ̣ ^ , organic \ . Á [~ ^ } æ̣æ̣ Á Á . [\ { Á Á ^ } & @] i | } ð' Á } æ̣æ̣ ð' Á Á [Á Á \ lobutan a etylenoxid Á Á [á à) . Á æ̣æ̣ æ̣æ̣ Á Á á á Á Á Á Á Á [0] . Á Á i | æ̣æ̣ Z ç i z ç ð' Á [: [i] [. c { Á Á } [ç æ̣æ̣ æ̣æ̣ ^ : ^ } & @ ç á Á Á ^ & @ Æ á Á Á [~ Á Á i] i } ^ Á æ̣æ̣ æ̣æ̣ ^ É \ c i . Á ç ç i ^ Á Á Á Á i } æ̣æ̣ . Á } æ̣æ̣ Á Á [\ [ç . Á] [c Á] æ̣æ̣ Æ á l u e n) .

! I d c n c f b b ̣

• Dci nY'cVg' i \ Ug' d YXydgUbc' i _ j U]z UWF

T æ̣æ̣ æ̣æ̣ | æ̣æ̣ Á Á á ^ | @ Á Á i | æ̣æ̣ æ̣æ̣ Á Á Á Á ç ^ } æ̣æ̣ . [á Æ c i i Á á ^ | @ Á] Á ç i i á Á æ̣æ̣ | æ̣æ̣ Á Á : i { ^ } æ̣æ̣ Á Á æ̣æ̣ æ̣æ̣ | æ̣æ̣ Á Á i | æ̣æ̣ æ̣æ̣



• I f Ybc' dci nY' YghUbcj Ybfa i ' • Yi'

Á i | æ̣æ̣ [Á Á æ̣æ̣ i 0 ^] [Á Á ^ i [á ^] [Á Á ^] ^ á á æ̣æ̣ Á Á & @ i | ^ } . Á Á æ̣æ̣ ^ { Á Á { [~ Á lwaki. Z i \ æ̣æ̣ Á [~ 0 ç æ̣æ̣ Á Á i | æ̣æ̣ [Á Á { Á Á 0 Á æ̣æ̣ [ç ^] { Á Á ^ i { Á Á æ̣æ̣ Á @ [: ð' } ^ á ^ :] ^ ð' Á æ̣æ̣ Á Á [z [: ^ } ð' Á i | æ̣æ̣ æ̣æ̣ Ú [~ 0 ç ^ Á Á i | æ̣æ̣ [Á Á ^ . } Á Á Á Á Á Á & @ æ̣æ̣ & @ á á Á Á [: . æ̣æ̣ Á Á 0 á Á Á i | æ̣æ̣ æ̣æ̣ Á Á ç æ̣æ̣ Á i { Á i [ç' á ^ } . Á { } ^ Á . } ^ Á á á á æ̣æ̣ Á Á i | æ̣æ̣ æ̣æ̣ [ç æ̣æ̣ ç Á Á { ~ Á waki } ^ á [Á i [á Á Á Á i | æ̣æ̣ æ̣æ̣



Nz_Uh

• YfdUX'c' ga fV yYhidci nY'gYghUbcj Yb a 'bUdz' YW a 'bUd ḥa' i j YXy b a 'bU' mdcj fa 'yḥḥ i "

Ṛ æ̣æ̣ Á @ [: ð' Á á ^ :] ^ Á Á i | @ Á Á i | æ̣æ̣ æ̣æ̣ [0 i i ~ Á Á i æ̣æ̣ Á Á \ d æ̣æ̣ { Á i [~ á ^ } .



Nz_Uh

• DfYj Ybhj ḅc̣dUh Yḅf̣d f̣ḥj' j nY' Yḅf̣ UdU]bmi

Ú i [ç ^ c Á ç @ á) i Á & @ æ̣æ̣ } i Á æ̣æ̣ ^ } ð' Á i | æ̣æ̣ æ̣æ̣ ^ Á } ð' Á æ̣æ̣ æ̣æ̣ ^ Æ ReÁæ: i: | [Á ^] [~ z c ç' á ^ :] ^ } [~ Á æ̣æ̣ æ̣æ̣ Æ Á Á ^ } [{ Á @ { Á [~ Á æ̣æ̣ æ̣æ̣ ^ , } æ̣æ̣ : ^ { Á Á á [Á [á æ̣æ̣ Á Á Á Á ç Á i [ç : ~ Á Á i | æ̣æ̣ æ̣æ̣ Á Á ç æ̣æ̣ æ̣æ̣ á ^ :] ^ } & @ Á c á á [á i 0 ^ Á Á Á Á } ç ç' á ^ } á ^ Á Á æ̣æ̣ æ̣æ̣ ^ } Æ



Dcncf

6 YndY bc'gh

⚠ I dcnfb b†

- YfdUX`c`bYga †V yYhibUgi W c.**

Zaa:ae c`&@ a` A^!| aai|aa' aa' &@ Aa^: Aa' aq' aq' ~ A`A^!| aai|a^). Sa`0A^!| aai|| A 0dA^: A \ aq' aq' ~ Eaa| &@: dA^A^: } a` A^| |aa' A c[a` A^) dA^: Aa^& d' Aa^ . d' A^ c[A^A^!| aai|aa' E &[0A] • [a` dA^ [z[: ^) dA^!| aai|aa' V . 0A^ a^:] ^ Eaa' A [A` dA^ Aa^ A^A^!| } ai &@&@ a` } aa' &@ A^A^ a` a` A^ [Aa^] aq' . A^ \ d [• aai|aa' . A^ a [b` Eaa



Nz_Uh

- I Xfji H'n'Xcgu i 'Hyd'UUC\ b "**

Zi \ ae A { o [c`aa' c`c` ^ } A` @ Aa' d' aai } Aa^] aq' A` ^ a { o` A^ | d \ [• dA^!| aai|aa' Eaa



Nz_Uh

- Nz_Uh'gci dzb†bU YfdUX`c.**

Zaa| a } &@ \ [] [• dA^!| [~ 0d^ A^A^!| aai|| Aa^ [A` d' aq' Aa^ Eaa' A aq' b` d' ~] . c` . Rq' a` Aa^ [: dA^ a^:] ^ dA^ | 0 } .. @ Aa^ : ae ~ Eaa



Nz_Uh

- BYXch_YH'gY YfdUX`U**

B`a [c \ ^ A^A^A^!| aai|aa' [d` a` dA^ | { aa' \ aq' aa' aa' @ a` A^!| aai|aa' } ^ a [Aa^ ^ a` A [A` @ A` • aai } dA^ d' aai Eaa' A^!| aai|| A [[~ 0dA^ A^!|] : aq' [@ | c . Aa' aq' ^ Aa^ @ A [c | &@ A^ a` dA^ a^:] ^ } Aa^ | E



Dcnfb

- DfcjY H'i nYa b b†**

Zi \ ae A` a` • | @ c`aa' A^!| aai|| Aa^: A` a [b } dA^ { } dA^ @ A [aa^ Eaa' a` Aa^ [: dA^ } ^ a^:] ^ dA^ : ae ~ A^ \ d' Aa^ { A [[~ a^ { Eaa' [] d [| ^ Aa' [b } dA^ { } dA^ @ A c [aa^ Aa^ [A^ { } dA^ c [| ^ Eaa



I nYa b b†

- Instali H'cW fUbb '†ghj '**

U` a` a` • | : ^ A^!| aai|aa' A` &@ aq' } .. @ Aa^ ca^ Aa^ [: dA^ : ae A^ | Eaa [| ~ a^ { E } Q • aq' Aa^ [| aq' } A` &@ aq' } Aa^ ca^ Aa^ [A^ • aai ^ A^!| aai|aa' Eaa



Ele tric_ fUh

- ?XY`bY`nY`]bghU`cj UhiUg`UXcj Uhi YfdUX`c**

- { o` aa' Aa^ | aq' { A [] ^ { Eaa' | aai | a` A
- { o` aa' : } a` A [| : dA^ } dA^ |] (chlor [c A [] } Aa^ [a` E
- { o` aa' Aa^ d . { } A` • [\ { Aa^ [] d' Aa^ [| aq' Aa^ 40 » C aq' z^) Aa^ d . { } } d \ { Aa^ [| aq' a` 0 » C aq' d .
- { o` aa' Aa^ A^ A^!| aai|| Aa^ • aai } [A } ae } . { ~ A | aai | aai | @ [• ca () ^ c \ | A^ A c^) \ [c] dA^ A^ [~)
- { o` aa' Aa^ Aa^ [&@ : dA^ Aa^ | aai d' .



Nz_Uh

- BUYH† YfdUX`U**

U` a` aq' [b` c] } dA^ d [a` A^ | Eaa'] ^ * a` A^!| aai|aa' [] d [| ^ Aa^] dA^ { } [• dA^ [a` A^ | | d] ^!| aai|aa' ^!| aai|| A [| A] d' ae Aa^ U` P W W E X Y U` P W W E U` a [b } d' Aa^ a^ ~ A` aai | aai | b` c ^ a^ c` A^!| aai|| Aa^ [&@ a` Eaa



Dcnfb

DCD'G''J FC6 ?I '

1. U~~á~~á cæ } ð~~á~~ áæ~~á~~ Á~~á~~ [} c [.æ..... ~~|||||~~
2. Princip Á } * [ç | } ð..... ~~|||||~~.....7
3. Qentifil a } ð~~á~~ 5á~~á~~ [á~~á~~..... ~~|||||~~.....
4. V~~á~~ @ ~~á~~ Á~~á~~ æ..... ~~|||||~~.....9
5. Ü [: { | ^..... ~~|||||~~.....9.
6. N | : ~~á~~á [^ | • c~~á~~á~~á~~ [| [ç ^ á ^ } ð~~á~~ ~~|||||~~.
- ~~|||||~~ æç } ð~~á~~ á ð~~á~~ ^ Á~~á~~ } æ ^ } ð~~á~~ ~~|||||~~ ~~|||||~~

1. CXghfUb bfcVUi 'U' cbhfc`U

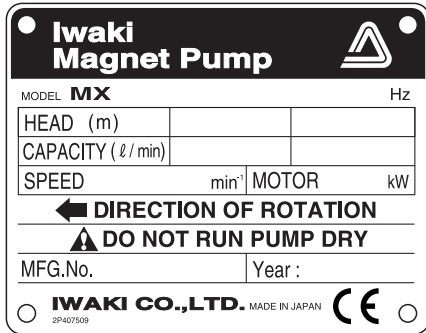

Rq'qf utcp p'qdcnw| nqpvqmwlg'p^a urgf wlf'p'Áf clg c'r qwt vg.'flg'f qf cp 'x tqdgnlc'lgj q'uqw^a uk'c'r tnm r gup 'qf r qx'f cl'xc-ff'qdlgf p^a xeg.

R k' xgf^a p'ff' gtr cf r' r quwr wlv'f r g'p^a xqf w' x'ner kqrg'4'Sk'pucwreg''pc'utcp '17.

[1] Qf r qx'ff^a "o qf gnlc'nö kq gv'wx^a f p 'pc'v{r qx² o "-v'ff'nmw' Áf cl o 'xg'xc-ff'qdlgf p^a xeg?

[2] P gf q-nj'd j go 'r gr tcx{ 'nir q-nq| gp'ff' gtr cf r' pgdq'lgj q" ^a u'ff' r qr 0'wxqrp p'ff'-tqwd "c'o c'ke'?

[3] ff'urq'O FG.No. wx^a f'ff'tqmix tqd{ 'l c ff' gp'ff'.
(r ff'm0) Mf {ff'r tx^a " ff'urleg'lg" "7".
7x2x2x
wtv^a " ff'urleg"x" ff'urq" MFG.No. wx^a f'ff'tqmix tqd{ " l c ff' gp'ff'.
"2" | pc ff'flg'x tqdgnld{ n| j qvqxgp'x'tqeg 2002.
(r ff'm02)'Mf {ff'r tx^a " ff'urleg'pgp'ff' "7".
xx2x2x
T g'ff' ff'urleg"x" ff'urq" MFG.No. wx^a f'ff'tqmix tqd{ " l c ff' gp'ff'0

X'r ff' cf 'l k-v p'ff'lcm ej nqrk'p'gutqxpcruv'ff'nqpvcmwlv'g" r tqf gleg.'w'mgt² j q'lug'wr r'v'pk'xc-ff'qdlgf p^a xnw0

2. Princip oVg'i V'm

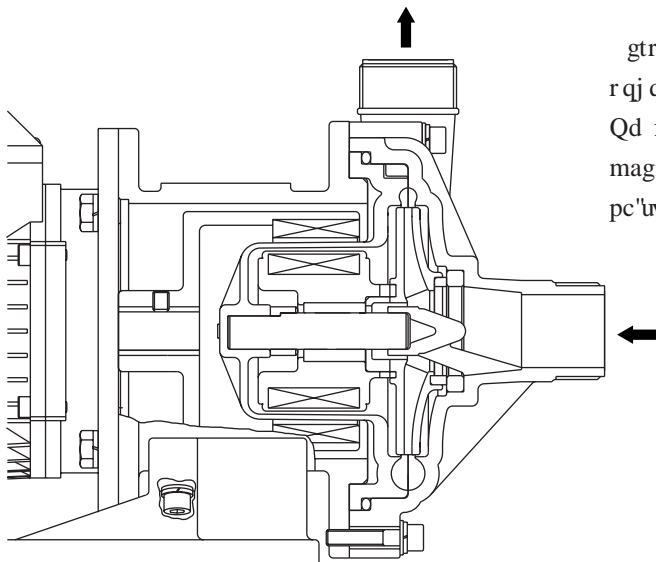

gtr cf r' MX lg'qf uv gf kx² " gtr cf r' u'gngmtqo ci p'gvem o " r qj qpgo 'c'r qwf'k^a 'ug'r tq't | p² "Á gn{.

Qd flp² 'nqmq'x'nqo q g" gtr cf r'(r gf p'ff'um'ff') ug'qv^a ff' magneticnq'w'ukr'w'r gp^a -gl'ff' h'cr c'kp'w| g'utcp{ 'u^a p'ff' pc'utcpw'x v'cmw0

→ : •{ |Á: q\`Áa'aa`Á

3. 3.1. 3.2. 3.3. 3.4. 3.5. 3.6. 3.7. 3.8. 3.9. 3.10. 3.11. 3.12. 3.13. 3.14. 3.15. 3.16. 3.17. 3.18. 3.19. 3.20. 3.21. 3.22. 3.23. 3.24. 3.25. 3.26. 3.27. 3.28. 3.29. 3.30. 3.31. 3.32. 3.33. 3.34. 3.35. 3.36. 3.37. 3.38. 3.39. 3.40. 3.41. 3.42. 3.43. 3.44. 3.45. 3.46. 3.47. 3.48. 3.49. 3.50. 3.51. 3.52. 3.53. 3.54. 3.55. 3.56. 3.57. 3.58. 3.59. 3.60. 3.61. 3.62. 3.63. 3.64. 3.65. 3.66. 3.67. 3.68. 3.69. 3.70. 3.71. 3.72. 3.73. 3.74. 3.75. 3.76. 3.77. 3.78. 3.79. 3.80. 3.81. 3.82. 3.83. 3.84. 3.85. 3.86. 3.87. 3.88. 3.89. 3.90. 3.91. 3.92. 3.93. 3.94. 3.95. 3.96. 3.97. 3.98. 3.99. 3.100.

MX – 400 C V 5 E

(1) (2) (3) (4) (5)

(1) S5ã | a } 0 ^ | i } ã | a } ã | a } \ [] ^ Á [d i ^ Á

S5ã	X a } 0 ^ i } ã a } ã a } D	X \ [] ^ Á otor
250	25A × 25A	0.37kW
251	25A × 25A	0.75kW
400	40A × 40A	0.37kW
401	40A × 40A	0.75kW
402, 402H	50A × 40A	1.5kW
403, 403H	50A × 40A	2.2kW

Rq | p 0 - Motor Ig 'T xqwr » m x . 'v 'f | q x

(2) T ã ^ | ã | á ^ 8 0 0 | • ð

C : w j r f n q x ^ 2 " n f l u n q × n g t c o l e n q / j n p f n q x ^ 2 " x g v p q

R : h w q t r r u v l e n ? " n f l u n q " u ' x r p f | × n g t c o l e n q / j n p f n q x ^ 2 " x g v p q

A : n g t c o l e n q / j n p f n q x ^ 2 " n f l u n q " × n g t c o l e n q / j n p f n q x ^ 2 " x g v p q (r t q M X - 2 5 0 c f l 4 0 1)

(3) T ã ^ | ã | Á Ü Ë | [^ 0 \

V : FKM

E : EPDM

A : Aflas®

(4) S5ã | à 0 } .. @ Á [| ã

5 : 50Hz

6 : 60Hz

(5) V ^] Á [d i ^ Á

E : u ' b q v t g o I E C

4. Hecle b'ic' f' • XUY

Model	Xia } ð Si } ðX qæ	S.G. limit	Max. : åçã@ (m)	Standarå } ð Specifiã a& (l/min, -m)	Max.]i ð \ [ç... { } [0• çð (l/min)	50/60Hz
						X \ [} { [ð i'
MX-250	25 × 25	1.0	15.5	50 – 14/13.5	150	0.37kW
MX-251	25 × 25	1.0	22	80 – 19	150	0.75kW
MX-400	40 × 40	1.2	12.5/11.5	100 – 10.5/10	280	0.37kW
MX-401	40 × 40	1.2	17.5/17	150 – 14.5	320	0.75kW
MX-402	50 × 40	1.2	26/23	200 – 20	450	1.5kW
MX-402H	50 × 40	1.0	31	100 – 30	160	1.5kW
MX-403	50 × 40	1.2	30	250 – 23	500	2.2kW
MX-403H	50 × 40	1.0	35.5/37	100 – 35	300/250	2.2kW

<a clbcgh YfdUXU (j "a clcfi)

MX-250, 400	MX-251, 401	MX-402, 402H	MX-403, 403H

5. Fcna fm

Model	W	H	L	a	b	c	d	e	f	g	i
MX-250	160	247.5		130	65	130	115	132.5	82.5	155.5	12
MX-251	160	247.5		130	65	130	115	132.5	82.5	163.5	12
MX-400	140	219		110	54	98	95	124	81	144	12
MX-401	160	249		130	72	130	115	134	97	178	12
MX-402(H), 403(H)	260	274		208	80	200	120	154	83	151	14×36

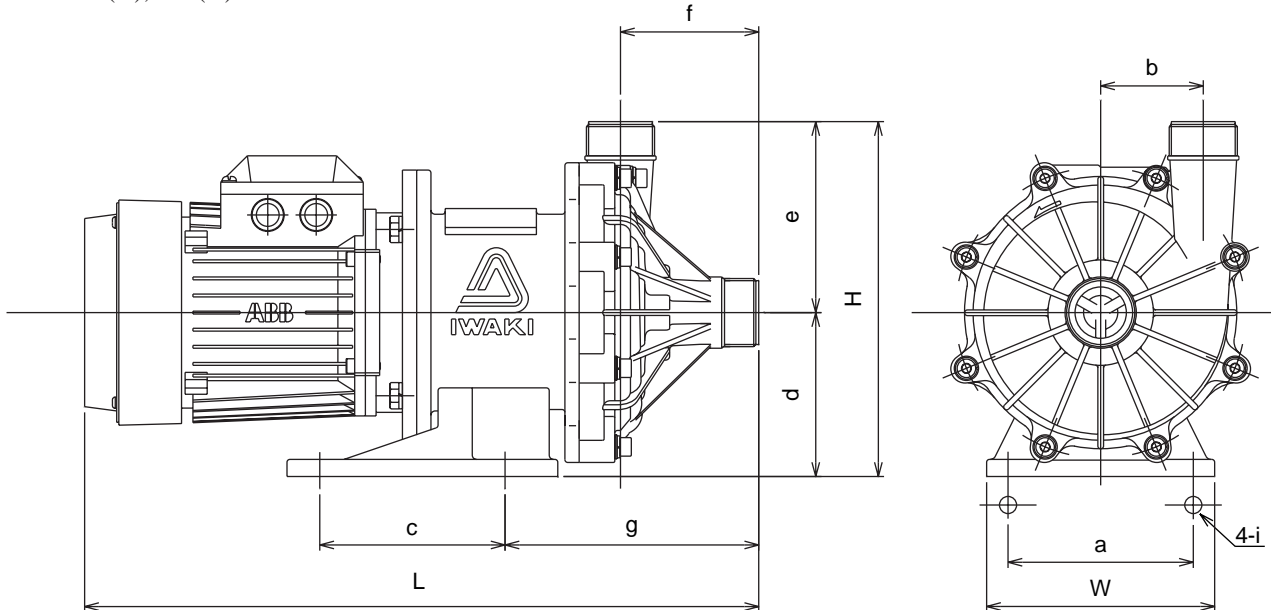

(2) MX-400

№	Nisat	T	Material	M	Nisat	Material			U
						CV	RV	AV	
1	gpm	1	GFRRR		18	J ngtco knc 99%			
2	cfp	1	GFRRR		19	CFRPPS			
3	Qd flp' hq	1	GFRRR		20	J ngtco knc 99.5%			
5	J pce'o ci pgo c 0	3	Feritqx "magnet + urkpc'j rpnw"		21	1	Fvqtq/ r t {un/ "leg"	J rpn ngtco knc 99%	
8	Rf - "grmtqo ci pgw	1	Feritqx magnet + polypropylen		22	Fvqtq r t {un/ leg'u'x r p"			
9	qwd'ug'8j tcpj rx04		Qegn	M8 x 87	23	HMO			JIS B 2401 G135
10	qwd'ug'8j tcpj rx06		Pgtgl 'qegn	M8 x 20, u' SW	2	Qegn			M8 x 20, u' PW, SW
11	qwd'ug'8j tcpj rx06		Pgtgl 'qegn	M8 x 30, u' PW, SW					
12	qwd'ug'8j tcpj rx04		Pgtgl 'qegn	M8 x 40, u' PW, SW					
15	Motor	1							
16	Rqf ucxc	1	GFRPP						
17	P' ucxcge	1	FC 200						

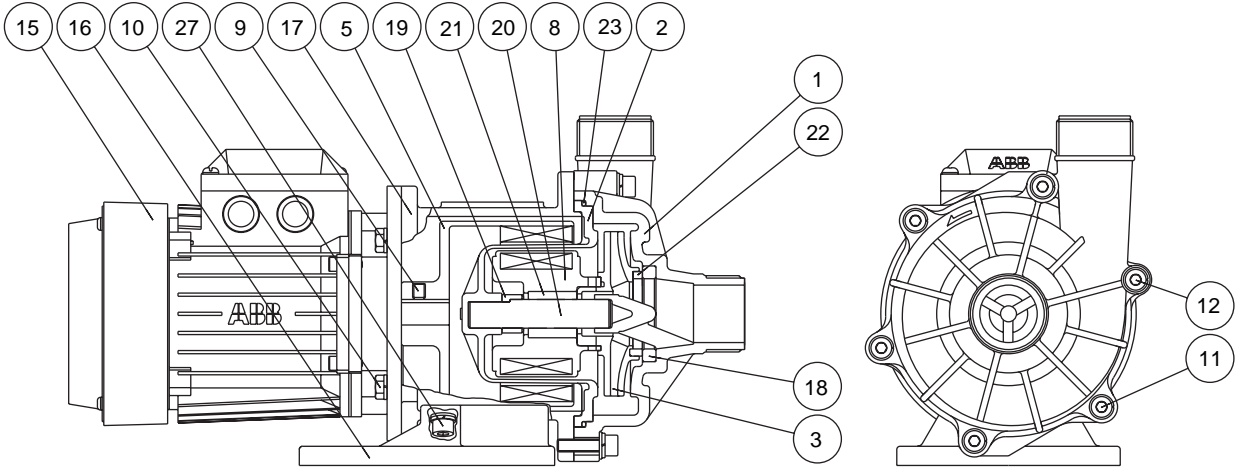

(3) MX-402(H)/403(H)

№	Nis ^ç	Zat aia	E	E	T	Materii		U() E	
						CV	RV		
1	R g f p	3	GFRPP	3	M q w f g n i x r q f l n	J n p	h n g t c o k n e 96%		
2	\ c f p	3	GFRPP	3	\ c f p	r	CFRPEEK		
3	Q d f l p	3	GFRPP	42	X g y p q	3	J n p	h n g t c o k n e 99.5%	
4	J p c e	1	Xi a e p o c i p g v + FCD 450	21	N q f l k u n q	3	W j r f m	F n w q t q r t { u n f l e g u x r p }	
8	R n f - g r g m t q o c i p g w	3	Xi a e p o c i p g v + polypropylen	22	- u p	1	H v q t q r t { u n f l e g u x r p }		
9	T g u n j t c p 0 t q w d	4	Q e g n	O : z	23	Q m t q w f g n i	3	H M O	JIS B 2401 G195
10	T g u n j t c p 0 t q w d	6	P g t g l q e g n	M10 x 30, u SW	26	T g u n j t c p 0 t q w d	4	Q e g n	M8 x 20 u PW, SW
11	T g u n j t c p 0 t q w d	7	P g t g l q e g n	M10 x 45 u PW, SW	27	R q l k u n e	2	GFRPPS	
12	T g u n j t c p 0 t q w d	1	P g t g l q e g n	M10 x 60 u PW, SW					
15	Motor	1							
16	\ a m f p c	1	GFRPP						
17	P a u c x g e	1	FC200						

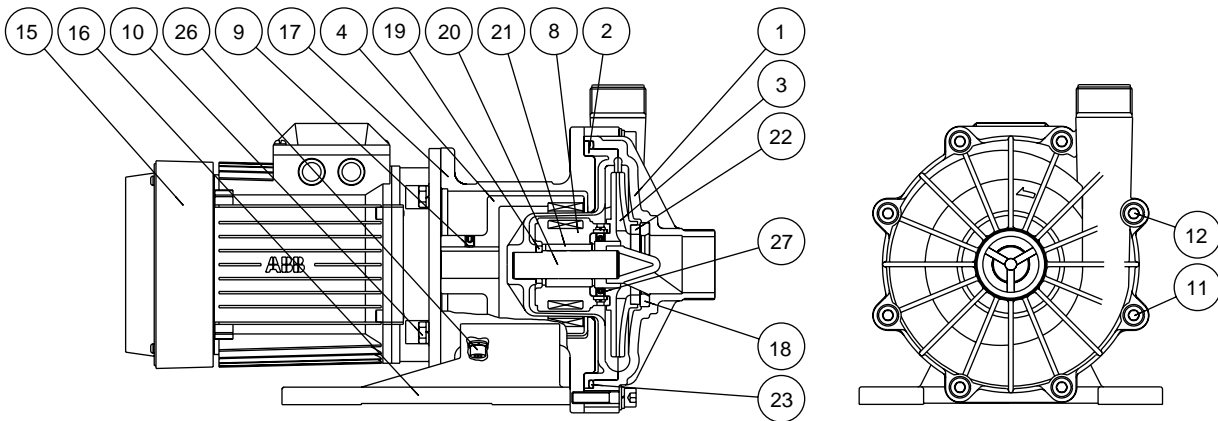

7. <`ajbř`gčĭ` zghĭ`UcnbU Ybř

5 [fY[zhĭ YfdUX`U(d`b bř_UdU]bci)

N^•ař [] aē | çãõãi` @] ^ãÁ]`zc } ě Á^!| aã|ãÁ
 } ař | c`Á^!| aã|| Ā[ā[`Á
 [c[i` Á aã | } ð
 aã çã`.

Chĭ cf`bUj ħU_i`

Chĭ cf`bUgzbř

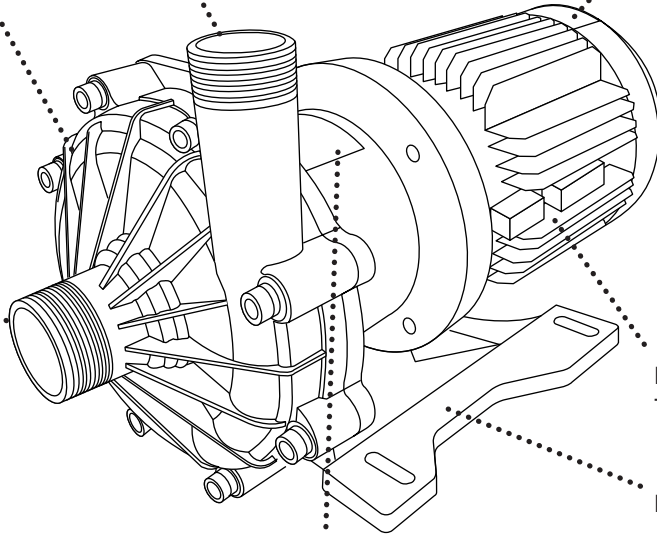

I_UhUř`ga fi`cřz Ybř

¥ã\ãÁ\ã`bÁ{ !Á
 [o ^) ě [d i` Ě
 X0ã`Á\} d i` ě
 :ãã [d i` Ě oõ^Á{ i`
 zã\`É

Motor (\ bUWř zgh)

T [d i` Ě [āi ç i Ā \ [] Á
 ^!| aã [ç. { `ã ě i`^* i c`.

Nz`UXbU

^!| aã [Ā `•õã cĭ^ç) Ā&@& } [.

Hmrcj`yĥřY`

^!| aã [Ā ^Á i [ç i : [çãĀ [` : ^
 :ãã cĭ [ç^) &@Ā [ā { ð ^\.

JUřcj bz`nbU`_U`Nã?5NDFCJCNCJ5H` 9FD58 @`B5`GI 7<C`

Ô@`ãÁ^!| aã|ãĀ`ãã^: Ā ař ařã`Ā] • [ãõ] [z [: ^) ð
 ç) ě\`Á^!| aã|ãĀR`Āãã i : i] [Ā i [ç i : [çãĀ^!| aã [Ā
 à^: Ā ař ařã`É

 I DCNCFB Bã

D J ĭyh bř YfdUX`UybYdci ĭř YřY`fncdci ýh XU`Yghřzbřřĥ ĭnbU Y`
 `Uh`YgU YfdUX`U.

Instalace

1. Úvod	15
2. Instalace	17
3. Průběh práce	19
4. Ověření výsledků	22

1. D' fUj U

⚠ I dcnfb b†

>YnU_znzbc`i j zX h YfdUX`c`Xc`W`cXi`bUgi`W`c

R gf`r tx o`ur w-v p`p " gtr cf n`r q`lgj q`kpuv`mek`f go qp`v flk` k`qr t`cx " p`cr n`v g`nqo`qt w` gtr cf n`n`er`c`k`p`q`w`
 wt`gp`q`w`h`n` gtr`a`p`OR`k`u`we`j`2`o`'e`j`q`f`w` gtr cf n`d`g`l`'n`er`c`k`p`{`|`r` u`q`d`g`l`'c`f`g`p`v`g`e`e`j`" `a`u`v`l`' gtr cf n`0`
 V`g`e`l`' `a`u`k`' gtr cf n`M`X`l`u`q`w`o`c`|`a`p`{`'c`'e`j`n`|`g`p`{`" gtr`c`p`q`w`h`er`c`k`p`q`w`0` gtr cf n`p`g`uo`'d`f`l`g`v`p`c`'u`we`j`q`'r`q`r`0`u`g`l`'e`g`r`
 w`l`c`x`g`p`o`'x`g`p`v`k`g`o`'p`c`'u`'p`OR`l`k`p`c`n`f`q`l`f`g`'h`r`q`-`n`q`|`g`p`l`' gtr cf n`0`X`'r`'f`c`f`'p`'a`j`q`f`p`2`j`q`'u`r`w`-`v`p`l`' gtr cf n`p`c`'u`we`j`q`'
 k`j`p`g`f`'x`{`r`p`v`g`'g`r`0`p`c`'a`l`g`p`l`'c`'p`g`e`j`v`g`" gtr cf n`q`'r`q`o`c`n`w`x`{`e`j`n`f`p`q`w`'r`q`'f`q`d`w`f`g`n`l`p`g`f`l`g`f`p`c`'j`q`f`k`p`c`.'F`q`r`q`t`w`w`l`g`o`g`
 r`q`w`f`v`q`e`j`t`c`p`w`K`Y`C`M`K`v`r`'F`T`'n`i`d`n`u`n`e`k`e`j`q`f`w`" gtr cf n`p`c`'u`we`j`q`0`

I`W`c`j`Y`h`r`'`Y`f`d`U`X`c`'n`X`c`g`U`i`'c`l`b`'`

M`l`c`o`g`l`g`p`l`'r`q`f`f`t`w`c`'x`d`w`e`j`w`p`g`w`o`'j`u`w`l`v`g`'p`g`d`g`l`r`g`p`2`'c`'j`q`m`x`2`'h`v`n`f`'x`'d`r`f`l`n`q`u`k`' gtr cf n`0`

B`Y`d`f`c`j`z`X`'h`r`'d`Y`g`h`j`V`i`'`

I`g`l`c`n`f`|`a`p`q`'r`t`q`x`a`f`v`r`g`u`v`c`x`d`w`" gtr cf n`0`P`g`d`g`l`r`g`'l`r`u`q`d`g`p`l`'A`l`o`{`'p`c`'l`f`t`c`x`l`'c`'A`t`c`l`w`'g`r`0`r`t`q`w`f`g`o`0`

1.6 YndY bcgfb`fcdUhYb`f`d`j`cVg`i`nY`YfdUX`U

1) D`g`l`r`g`p`q`u`v`l`q`r`e`v`g`p`l`'r`k`p`c`l`f`f`f`p`l`'c`'q`f`u`v`c`x`q`x`a`p`l`' gtr cf n`"

M`l`c`o`g`l`g`p`l`'x`q`f`p`l`'j`q`'t`a`|`w`x`p`w`l`v`g`'r`k`u`r`q`w`-`v`p`l`'c`'q`f`u`v`c`x`q`x`a`p`l`' gtr cf n`'r`q`l`q`p`q`u`v`p`a`u`r`g`f`w`l`p`e`p`o`'d`q`f`o`0`

R`q`'p`g`l`v`g`'u`k`l`x`n`i`-`'r`q`l`q`p`'x`'r`'f`c`f`'f`n`q`w`j`2`j`q`'r`q`w`d`l`p`c`'x`v`c`n`w`0`

a. R`k`u`r`q`w`-`v`p`l`' gtr cf n`"

R`q`'p`c`r`i`p`p`l`' gtr cf n`n`er`c`k`p`q`w`p`g`l`c`r`q`o`g`v`g`l`e`g`r`'c`x`'l`v`x`g`p`v`k`l`p`c`'x`v`c`n`w`f`'k`g`'p`g`f`l`'C`R`P`G`V`G`'g`r`0`r`t`q`w`f`"n`g`
 u`r`w`-`v`p`l`' gtr cf n`0`R`q`'p`c`l`g`l`' gtr cf n`'r`q`o`c`n`w`q`v`x`f`l`g`l`v`g`x`g`p`v`k`l`p`c`'u`t`c`p`'x`v`c`n`w`n`f`q`u`c`f`l`g`p`l`'r`q`l`c`f`q`x`c`p`2`j`q`'x`n`q`p`w`.

b. R`k`q`f`u`v`c`x`q`x`a`p`l`' gtr cf n`"

R`q`o`c`n`w`l`c`x`f`l`g`l`v`g`'x`g`p`v`k`l`p`c`'u`t`c`p`'x`v`c`n`w`c`'r`q`"A`r`p`2`o`'w`l`c`x`g`p`l`'x`g`p`v`k`w`X`[`R`P`V`G`'r`'k`q`f`'g`r`g`m`t`l`e`n`i`"`
 g`p`g`t`i`l`g`.

>YnU_znzbc`bz\`Y`n`U`j`f`U`h`d`c`f`i`V`f`b`U`j`h`U`_i`'d`c`a`c`W`f`Y`Y`_f`c`a`U`l`b`Y`h`j`W`_f`j`Y`b`h`i`'U`d`c`X`"B`z`l`'`a`'i`n`U`j`Y`b`f`a`
 d`c`l`f`i`V`f`b`U`g`f`U`b`'j`h`U`_i`'n`d`g`c`V`h`j`c`X`b`f`z`n`g`'b`z`g`'Y`X`b`a`'d`c`y`_c`n`Y`b`f`a`'`Y`f`d`U`X`U`.

2) I`g`l`c`n`f`|`a`p`q`'l`p`u`v`c`x`c`v`c`'u`m`f`q`x`c`v`' gtr cf n`p`c`'p`a`u`r`g`f`w`l`p`e`e`j`'o`'j`u`v`e`j`<

- o`'j`u`q`.'n`f`g`'v`r`n`q`v`'m`g`u`f`'r`q`f`'0`A`C`
- o`'j`u`q`'u`'x`u`n`f`v`g`o`'n`q`t`q`l`'k`p`e`j`'r`n`{`p`'c`'x`d`w`-`p`e`j`'r`n`{`p`" `
- o`'j`u`q`.'n`f`g`'f`q`e`j`'a`|`'h`n`t`q`l`u`v`k`w`'x`q`f`{`'(x`l`k`o`n`q`w`l`u`q`w`" gtr cf n`'u`o`q`v`t`g`o`'q`f`q`p`o`'r`t`q`v`k`r`q`x`v`p`q`u`v`p`'o`'x`r`k`o`)
- o`'j`u`q`.'n`f`g`'q`n`q`p`l`'v`r`n`q`v`'r`g`x`{-`w`l`g`"40`A`C`
- o`'j`u`q`'u`'x`u`n`f`v`g`o`'x`i`j`n`q`u`k`'(r`'f`w`u`p`a`'x`i`j`n`q`u`v`:'35`c`f`l`85`%'R`X`)
- o`'j`u`q`'u`'p`g`d`g`l`r`g`'p`o`'r`t`c`e`j`w`'r`q`f`f`t`w`'l`g`o`'v`g`u`g`p`l`'c`'x`p`l`-`e`j`'p`a`t`c`l`'.

3) P`c`r`n`v`g`" gtr cf n`n`er`c`k`p`q`w`

gtr cf n`q`'p`g`p`l`'u`c`o`q`p`c`u`'x`c`e`OR`g`f`'u`r`w`-`v`p`l`'o`" gtr cf n`"p`c`r`n`v`g`" gtr cf n`n`er`c`k`p`q`w`E`j`q`f`'p`c`'u`we`j`q`l`r`u`q`d`l`'c`f`g`p`l`'
 c`'t`{`e`j`i`f`'q`r`q`v`g`d`g`p`l`'u`q`w`'a`u`v`g`n`l`' gtr cf n`.'f`a`n`g`'r`q`'w`n`{`p`w`l`'x`'e`g`e`l`c`m`52`'u`g`m`w`p`f`'u`g`'f`q`u`v`c`x`l`p`g`d`g`l`r`g`p`2`'g`r`g`m`t`q`u`v`c`l`e`n`i`
 x`d`q`l`g`" gtr cf n`0`

2. Instalà WY

⚠ JUfcj zbf

JMDB H9`d j cX`Y`"YbYf [JY`

R k'r t`a ek'pc' c q' gp'X[RP VG'r q'xqf "gr0'gppti kg0\ clkuv vg.'cd{ 'p'gf q-n'v gdc'kl'gp'n'hp`a j qf p`2 o w'w'gf gp'f q" r tqxq\ w'd j go 'x{ n'qp`a x`a p'q'r t`a eg'pc' c q' gp'0X`j nw p`2 o 'r tquv gf q'pgdq'r tquv gf q'ug`-r c'v'p'q'w'x'k'f k'g'p'q'u'v'q'r quvcx'v'g x ut'c'f'p'q'w'j pc nw'w'ur 'p'c g'gr0'r tqw'f w'u'w'r q\ qtp p'p'p' . 'flg'\$Rtqd'j`a 'r t`a eg'\$'pc" gtr cf r'g0'

D J`d Ybz`Yb`z YfdUX`U`Y`"bYga j`Y`i W cd]h`n`U zgh`j`nfcVYb`f`n`d`Ugh`i

R go q'u q'x'c'p`2" gtr cf r'q' P GUO`VG'vej q'r k'v' c'lg'j q'r r'c'v'k'w' " a u'k'l'c'n'q'lg'um'q' . 'r q'f'w'c'p'g'd'q'`a m'c'f'p'c. I'k'p'c'n'j' t'q'l' q' r t'c'v'p'w'q'r r'c'v'k'w' e'j 'f' q'p' "c'ug'j`a p'q'" gtr cf r'c'v'k'w' u'p`a u'g'f'p o 'r q't'c'p p'q'p' 'quqd0 J o q'v'p'q'u'v' gtr cf r'c'v'k'w' k'p'q'f'ec"30 kg max. K'p'v'c'w'v'g" gtr cf r'q' ur q'n'w'u'm'ot'orgo 'f' q'x'q'f' q't'q'x'p`2 'r q'm'j { 'ug'`l`a m'c'f'p'q'w'w'o t'go 'f' q'n 0'

DfzW`bUY`Y`_f`jW`_f`a`n`U`_j`Yb`z`

Ergmt'q'r t`a eg'lg'`q'r t`a x'p p'r tqx`a`f v'g'rg'mt'k'n' 'u'r g'f'g'r u'c'p'q'w'h'x'c'n'k'w'c'f' I'k'p'c'n'j' t'q'l' q' r q't'c'p p'q'q'u'd'c`-n'q'f'c'p'c'o c'lg'w'v'0'

● I _zn_Udc'f'i V`j`

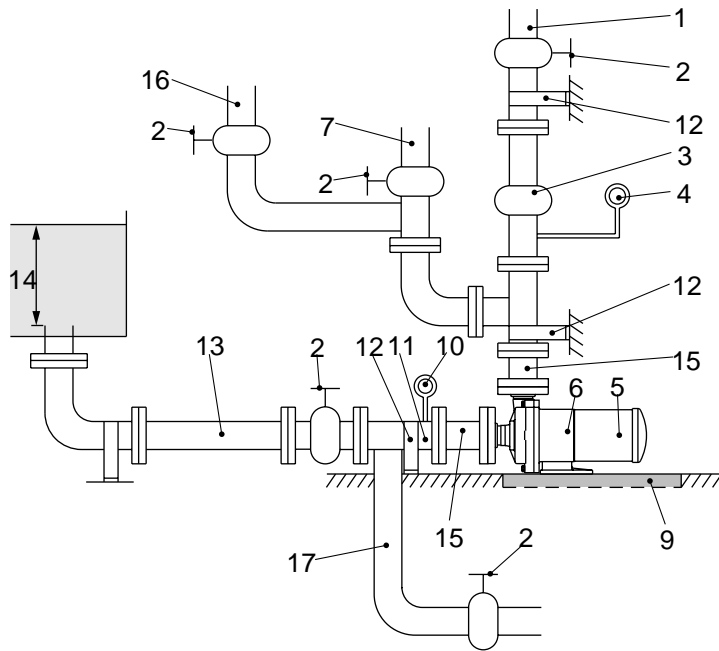

- | | |
|--|---|
| (1) X w'c p`2 'r q'v'w'd'q' (r q'v'w'd'q' c'lk'v' v'g' r' q'f'r t'q'w'cd{ " I'p' " gtr cf r'q' p'g'd{ m'j' c'v'f'lg'p'q) | (11) S'c'e'q'r q'v'w'd'q' (r t o t' r' q'v'w'd'q' : D) (X'q'f' q't'q'x'p`a " a u'v'o w'w'f'd' v'e'q'p'g'l'm'c'v'q' u'g'w'q'w`a p'p' " 1/100 uo t'go 'm' gtr cf r'w) |
| (2) V'g'p'v'k'n | (12) P'q'f'r t'c' r' q'v'w'd'q' |
| (3) \ r v'p`a "m'c'r n'c | (13) S'c'e'q'r q'v'w'd'q' (r t o t: D) |
| (4) V'r'c'n'q'o t" | (14) 2D, 500 mm c'x`-g" |
| (5) M'ot'or | (15) X{ t'q'x'p`a x'c'e'q'ur q'l" |
| (6) g't'r c'f' r'q' | (16) R't'q'r m'e'j' q'x'c'e'q'r q'v'w'd'q' (u't'c'p'c'x` v'r'c'w) |
| (7) Q'f' x f'w- q'x'c'e'q'r q'v'w'd'q'" | (17) R't'q'r m'e'j' q'x'c'e'q'r q'v'w'd'q' (u't'c'p'c'ur`a p'q') |
| (9) Q'f' n'e'q'x'c'e'q'r n'e'p`a`n' | |
| (10) V'a'm'x'q'o g't" | |

1) Instala } 01 [[00A

- Instalwlg" gtr cf nq'p'gldm'f'g'uce'p'a f tfig'c'x'p'g'p'k'f'-'o q'f'p'2 'r qm' g (l 'f' xqf w'f' p'f'r qf' 'a r'k'x'go -0)
- X'r 'f' cf . 'f'g'uce'q'x'q't' gtr cf n' d'w'f' g'w'o 'f'uv' p'x' -g'p'g'f' 'uce'p'a f t'f'l (n'x' r'k'uce'x' -eg), | c'k'uv' v'g' 'k'p'uc'v'ek'r' c'v'p'f' q' x'g'p'w'x'r' m'p'f'p' 'r' q'v'w'f'c' 'uce'p' 'r' q'v'w'f'0
- * F'q'r' t'c'x'p'x' -n'e' 'a' x'k'f'p'c'x' r'c'v'p'q'v'g'e'j' 'n'c'r' c'k'p' { . 'l'g'l'v'g'r' m'v' 'c'f'2' r'g' 'uce'f'j' q' 'r' q'v'w'f'f' 'R'q'f' t'q'd'p'q'w'k'p'c'v'c'x'g'p'f' n'q'p'l' w'w'w'v'g'u'h't'o' q'w'k'y' c'n'k'p'g'd'q'x'c-'p' 'r' t'q'f' g'leg'o' 0

2) Áx} 0c} 000A^} \ [ç} 01 [~ 000A

gtr cf nq' h' g' r' t'q'x'q'l' q'x'c'v' 'c'n'k'x'g'x'g'p'n'q'x'p'p' 'r' t'q'v'g'f' '0' X'f'f' { 'x'c'n'f'r' t'q'x'g' v'g' 'd'g'l' r'g' / p'q'v'p'f'q'r' c'v'g'p'f'p'c' 'q'e'j' t'c'p'w'o' q'v'q't'w'c' 't'q'l' x'q'f' p'2' j' q'l' c' 'f' g'p'f'g'r'0'g'p'g't'i' k'g' 'r' t'q'w'k' 'a' r' r'c'x'a' o' 'c' 'l'k'p' o' 'f'k'x'g'p' o' 'r' q'j' t'q'o' 'a' o' 0'

3) Á 0 ç} 00 • 000A^

\ x'q'ng' 'c'n'q'x'2' 'o' 'f'v'q' 'n'k'p'uc'v'ek' gtr cf n' . 'm'g't'2' 'l'g' 't'q'x'p'2' 'c' 'l' d'c'x'g'p'2' 'x'k'd't'c'e'f'f' 'r' u'q'd'g'p' e'j' 'q'n'q'p'f'p' k'w'v'q'l'k'0\ c'k'uv' v'g' f'q'uc'v'g' p' 'r' t'q'v'q't' 'r' t'q' 'Á'f'f'f'd'w'0

● Nz_`UXcj f'dfzWw

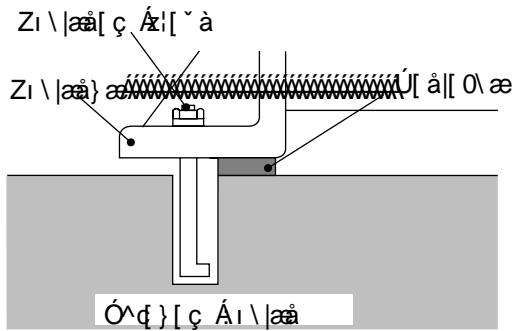

- 1) R'q'e'j' c' 'r' t'q' 'w'w'v'g'p'f' gtr cf n' 'o' w'f' 'd' v'x' v-'f'p'g'f'l' r' m'c'f' p'f' . X'r' 'f' cf 'p'g'f' q'uc' w'f'p'f' 'n'q'v'g'p'f' r' m'c'j' { 'o' w' u'f'f'g' 'a' m'c'f' p'w'l' p'k' k'v'p'g'd'q' 'l'g'x' { u'v'c'x'g'p'c'x' { u'q'n'2' o' w'o' t'p'2' o' w'l' c'v'f'f'g'p'f' .
- 2) M'f' { f'l'g' 'r' t'q'x'q'l' " gtr cf n' 'x' { u'v'c'x'g'p' 'r' u'q'd'g'p'f' 'x'k'd't'c'e'f'f' 'p'c'r' 0't'g'l' q'p'c'p'eg' u' 'r' q'v'w'f'p' +.' 'c'k'uv' v'g'x' { t'q'x'p'a' x'c'e'f'f'ur' q'l' "f' k'c'v'ek'+ o' g'l' k' gtr cf r'g'o' 'c' 'r' q'v'w'f'p' 0'l'k'p'c'n'f'j' t'q'l' 'f' 'r' q-'m'q'l' g'p'f' 'r' q'v'w'f'f' 'o' k'f' n' 'c'v'f' 00

3. Pchfi V#

● D jdc Yb#dchfi V#

P^a urgf wl^e¶\cdwmc'wx^a f¶\xgrknquv'-tqwdw'c'bo qo gpv'wcflep¶r qvwdp¶r ¶r qlm¶ 'hnr ¶twd^a o " gtr cf n0

Fqf tflwg'tq| o t'-tqwdw'c'bo qo gpv'wcflep¶ (J qf pqv¶ 'x'Vcdweg'r n¶¶r tq'huqxqqr ¶twdw'a r t {flqx²'v up p¶})

M [á^]	X^ á • c¶: [~ á ~ /M [{ ^ } c¶ cæ^ } á(N.m)
MX-250, 251, 400, 401, 402, 403	M16 20

● 'NUhyYb#U\ mVbcghdchfi V#

P¶flg'lg'wxgf gpq'f qxqrgp²'pco^a j^a p¶c'bo qo gpv¶ 'u¶¶r 'r uqd¶¶pc'r ¶r qlp 'u{v² o " gtr cf n0

Rqvw¶¶bo w¶¶d 'vpcxtflgpq'c'hwpi qxcv'cm'flg" gtr cf m'pgdwf g'x {ucxgpq'r pw¶¶c'bo qo gpv o 'uknr gucj wl¶¶¶} j qf pqv¶ 'wxgf gp²'x'p^a urgf wl^e¶ej 'Vcdwmi ej 0'

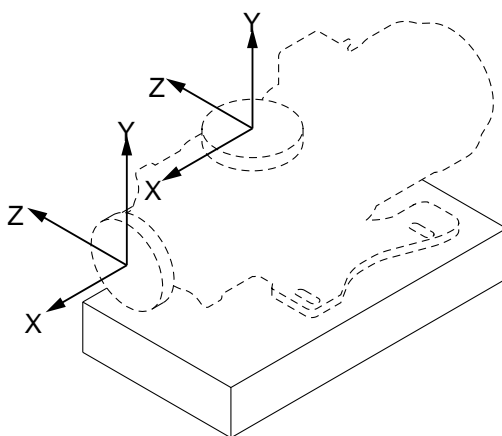

Ö [ç [^ } | Á | c OÁ [d' áð' áç çæ] [~ Á ð' á' ~

	Ú: { Á d' áð'(mm)	
	25	40
	\ ^a v fl	
Úç Á c O^	kN	
Fx	0.10	0.15
Fy: uvr gp¶	0.15	0.20
Fy: pcr ¶p ^a p¶	0.10	0.10
Fz	0.10	0.15

Ö [ç [^ } | Á | c OÁ [d' áð' áç çæ] [~ Á ð' á' ~

	Ú: { Á d' áð'(mm)	
	25	40, 50
	\ ^a v fl	
Úç Á c O^	kN	
Fx	0.10	0.10
Fy	0.10	0.15
Fz	0.10	0.15

Ö [ç [^ } .Á [{ ^ } c Á [d' áð' áç çæ] [~ Á ð' á' ~

	Ú: { Á d' áð'(mm)	
	25	40
	\ ^a v fl	
Úç Á c O^	kN·m	
Mx	0.02	0.05
My	0.05	0.10
Mz	0.05	0.10

Ö [ç [^ } .Á [{ ^ } c Á [d' áð' áç çæ] [~ Á ð' á' ~

	Ú: { Á d' áð'(mm)	
	25	40, 50
	\ ^a v fl	
Úç Á c O^	kN·m	
Mx	0.05	0.10
My	0.02	0.05
Mz	0.05	0.10

● **'Dcffi VfbUgffUb 'gzbf**

- (1) Rqtwd¶pc'ur p¶o wuf'f rg'o qfbqur' tceqxcvr' tpekr w'ur p¶'r qf' | a rægo . Rqtwd¶o wuf'd v'eq'pglntcv-¶ c'u'ò kþko a p¶'o 'r q vgo 'qj { d 0\ clkv vg'qf' r qx¶f cl¶'r qf r tw'uce¶¶ q'r qvtd¶¶' pcr 0hqtø qw"x { tqxp'a xce¶¶ q ur qlg'cr qf 0'cd { 'x'a j c'c'vgr gp² pco a j a p¶'r qvtd¶¶' ug'pgr gp² -gn¶ 'pc' gtr cf n¶0
- (2) P cuc vgr'g ræx 'ur qlmw'pc'uce¶¶'r qvtd¶¶' cd { 'f'q'xgf gp¶¶' p gxpknæix | f wej 0X un¶ v'x | f wej w'x'uce¶¶'o 'r qvtd¶¶' o flg'r q-n¶f k'f cp 'u { ur² o 0'
- (3) R k'þgx { j qxw'¶e'¶'o 'ur p¶' (p cr 0r qf vænix 'uce¶¶' p'a ftf¶¶' 'xgm¶' p'a vnrqx'a x -næ, r qr 0f n¶w j ² 'uce¶¶'r qvtd¶¶' ¶' o wuf'g'tger¶¶ qxcv'væx $NPSHa > NPSHr + 0.5\text{ m}$. Qj r¶f p 'x -g NPSHr x¶¶ 'uæpf ctf p¶¶'x n¶p qx'a mæx næ0
- (4) R k'r qwfkw'¶ n¶rgpc'pc'utæp 'ur p¶' instalw'v't qxpqw't wdmw'q'f² ræg'o kþ0500 mm pgdq 8o k'p'a uqdgnæ r t o tw'uce¶¶' q' qvxqt w'r g' qvxqt go 'pc'ur p¶' gtr cf n¶0 \ clkv vg'eq'o qfb'a 'p glx v-¶¶' r qn¶o t'R n¶rgpc.
- (5) P gr kr wu vgr' ¶ cf p² 'x uwr n¶ . 'nf g'o flg'f qej a | gv'n | cej { egp'¶' | f wej w'r qf² n'uce¶¶' q'r qvtd¶¶' ¶ Rqtwd¶¶pc'utæp " ur p¶'o a 'uqrw'a p¶¶' 1/100 uo tgo 'ni' gtr cf n¶0

$X' \text{ @ } \checkmark \text{ } \text{\textcircled{A}} \text{ \textcircled{c}}$	$p \wedge] \text{ } \text{\textcircled{a}} \text{ }] \text{ } \text{\textcircled{A}} \text{ \textcircled{c}}$
<p>$X' \text{ @ } \checkmark \text{ } \text{\textcircled{A}} \text{ \textcircled{c}}$</p>	<p>$N \wedge \checkmark \text{ @ } \checkmark \text{ } \text{\textcircled{A}} \text{ \textcircled{c}}$</p>
<p>$X' \text{ @ } \checkmark \text{ } \text{\textcircled{A}} \text{ \textcircled{c}}$</p>	<p>$N \wedge \checkmark \text{ @ } \checkmark \text{ } \text{\textcircled{A}} \text{ \textcircled{c}}$</p>
<p>$X' \text{ @ } \checkmark \text{ } \text{\textcircled{A}} \text{ \textcircled{c}}$</p>	<p>$N \wedge \checkmark \text{ @ } \checkmark \text{ } \text{\textcircled{A}} \text{ \textcircled{c}}$</p>
<p>$X' \text{ @ } \checkmark \text{ } \text{\textcircled{A}} \text{ \textcircled{c}}$</p>	<p>$N \wedge \checkmark \text{ @ } \checkmark \text{ } \text{\textcircled{A}} \text{ \textcircled{c}}$</p>

- (6) X'r ƒcf 'tq|fƒp ej 'rt o tw'qwtw'pc'ur'p' gtrcfm'c'uceƒj q'r qvtd'ƒr qwfll'g'gzeqvtlenqwt'gf wnek R kr ql'g'gzeqvtlenqwt'gf wnek'cm'fig'j qtp'ƒr me'j c'lg'x'tqxl'p . X'f'f'p'2 o 'r ƒcf 'pgn'g'r qwf'ƒ'uceƒ' r qvtd'ƒ q'rt o tw'o gp-ƒ'o 'pgf'lg'qwt'pc'ur'p'0
- (7) Tqxp fl'ug'fqrqt wlg'x'r ƒcf 'ur'p'ug' ƒ r'xgo 'ƒpucnqxcv'pc'uceƒ'o 'r qvtd'ƒ-qw' "m'wupcf p p'ƒi gpgt'ƒp'ƒ nupvtqnl'" gtrcfm. R k'd fl'p'2 o 'rtqxq| w' gtrcfm' o wu'ƒ'd v'-qw' 'pcr'p'q'q'v'g'p'2 ='-qw' 'p'w'p'q'| c'x ƒ'v'r q'w' g' r gf' ƒi gpgt'ƒp'ƒ nupvtqnt'w'0
- (8) Mf { fl'lg'ekn'w'q'x'ƒ'pc'p'gdg| r g p'ƒ 'n'cr'c'k'p'c, | c'k'uv' v'g'r t'q'r n'ej q'x'c'ƒ' r qvtd'ƒ' m'w'o q'f'p p'ƒ'x'p'k'v'p'ƒ' q'x'ƒ' k'v'p'ƒ' r q'f' go q'p'v' fl'k' gtrcfm'0
- (9) Rt o t'uceƒ'j q'r qvtd'ƒ'o wu'ƒ'd v'x v-ƒ'pgf'ƒ'rt o t'qwtw'pc'ur'p' gtrcfm'0

Úo: } È } 0 ^ Á ç ^ á ^ } . . . [á ^ (10), (11), a (12)] | æ 0 1 ; [Á ^ ç á ^ Á æ 0 1 ç z ^ Ë

- (10) \ cnq'p gp'ƒ' r qvtd'ƒ'pc'ur'p' o wu'ƒ'd v'w'o ƒ'iv'p'q'500 mm c'x'ƒ'g'r'q'f' r q'x'tej go 'n'cr'c'k'p'c'0
- (11) P'c'x'uw'r 'uceƒ'j'p'ƒ'f't'f'lg'p'c'uc' v'g'ur'ƒ'q'm' co g| gp'ƒ' r ƒ'ur'w'w'ek' ƒ'ej' " ƒ' u'ke'f'q'uceƒ'j q'r qvtd'ƒ'0 \ cnq'p gp'ƒ'uceƒ'j q'r qvtd'ƒ' o wu'ƒ'd v'x' f'ƒ' r'p'2 "1~1.5 D (D: rt o t'uceƒ'j q'r qvtd'ƒ') c'x'ƒ'g'r'q'f' f'pc'uceƒ'j'p'ƒ'f't'f'lg'0 Rq| qt.'x'p'k'p'w'ƒ'ek' ƒ' ƒ' u'ke'g'o fl'g' r u'q'dk'v'r'q't'w'ej w' gtrcfm'0
- (12) X'r ƒcf 'o g'v'q'f' { 'uceƒ'j'x' -m'ƒ' 'o wu'ƒ'g'p'c'uceƒ'j' o 'r qvtd'ƒ' ƒ'p'ucnqxcv'ƒ' c'v'p'ƒ'x'g'p'k'ƒ'0

● 'J hU bf'dchfi Vƒ'

- (1) ƒ'p'ucn'w'v'g'r'q'f'r tw'cd' { 'j o q'v'p'qu'v'r qvtd'ƒ' ƒ'p'gr u'q'd'k'ƒ'pc' gtrcfm' ƒ'cnq' ƒ' ƒ' v' fl'0
- (2) X'r ƒcf 'r'q'w'f'k'ƒ' ƒ'lp'2'j'q' r u'q'd'w'p'g'f'lg'ur'p'ug' ƒ' r'xgo 'o wu'ƒ'g' ƒ'p'ucnqxcv'ƒ' p'ƒ'ƒ' r qvtd'ƒ'0
- (3) U'r ƒ'ƒ'k'ƒ'f'iq'w'j o 'r qvtd'ƒ' o 'u'q'w'ƒ' k'lg'j'q'q'f'r'qt.'eq'f' ƒ' v' fl'w'lg'x' n'q'p' gtrcfm'0 Rt o t'r qvtd'ƒ' " u'g' ƒ'uc'p'q'x'ƒ'pc' ƒ' ƒ' m'ƒ' 'x' r'q' w'q'f'r'q't'w'r' qvtd'ƒ'0
- (4) X'r ƒcf ' .fl'g'p'c'uc'p'g'p' n'gt'ƒ' ƒ' 'p'ƒ' u'rg'f' w'ƒ'ƒ'ƒ'ej 'u'k'w'c'ƒ' ƒ' o wu'ƒ'g' ƒ'p'ucnqxcv' ƒ' r v'p'q'w' m'cr' n'w' R k'x'q'nd' ƒ' r v'p'2 'm'cr' n'ƒ' " t'q|j'q'f' w'lg'w'c'n'q'x'ƒ' j' t'c'p'leg' ƒ' r v'p'2 'm'cr' n'ƒ' (x' g'p' 'x'ix'w'x'q'f'p'ƒ' q't'ƒ' | w'c' ƒ' r v'p'2'j'q'v'q'm'w' p'c' gtrcfm'j).
 - ① x w'c' p'2' r qvtd'ƒ' ƒ'lg'r ƒ'ƒ'k'ƒ'f'iq'w'j'2"
 - ② x w'c' p'ƒ' x' -m'ƒ' r g'x' { -w'lg' 15 m
 - ③ | cnq'p gp'ƒ'x' w'c' p'2'j'q' r qvtd'ƒ' ƒ'lg'q'9' m'x' -g'p'g'f'ƒ' r q'x'tej 'uceƒ'j'p'ƒ'f't'f'lg' "
 - ④ p' n'q'ƒ'k'm' gtrcfm' ƒ'gn'lg'r'c't'c'ng'p' 'x' ƒ' ƒ' go p' r'q'r'q'lg'p'q'pc' ƒ'lg'f'p'q' r qvtd'ƒ' ƒ'

- (5) Fqrqtw wlg'ug'pc'x wε p²'r qtwd'k'pucnqxcv'xgpv'k'it'gi wεek'qdlgo w'x wεmw'c'm' co gl gp'f'r g'v'f'gp'f' o qqtw0X'r 'f'cf 'k'pucnqeg'lcni' r v'p²'mεr n'f'v'cni'xgpv'kw'o wu'f'd v'f' r v'p²'mεr nε'wo 'f'iv pc'o gl k' gtr cf rgo 'c'xgpv'k'go 0'
- (6) P gl cr qo g v'g'k'pucnqxcv'wεnqo t'pc'x wε p²'o 'r qtwd'f'0'
- (7) Instalw'g'qf x'f w- qxcε'f'xgpv'k'x'r 'f'cf . 'f'lg'x wε p²'r qtwd'f'lg'x'g'xqf qtqxp²'r qnq' g'xg'w k'f'iqwj ²0'
- (8) Czkuw'g'rk'p'gdgl r g 'f' co t'f'pw'f'ner c'k'p'f'x'g'x wε p²'o 'r qtwd'f'k'instalw'g'x'f'r qw-v ε'f'xgpv'k'it'qf nεr'gp'f'ner c'k'p'f'.

4. 9`Y_hfc]bghUUV

Ele_kf]W_f'd_kc^_m

DCNCF

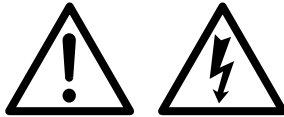

Ò^dæ.Á q[b}ð{ ð!:[çí á ó[~: ^Á| ^däí ÁÁ ^á^} •æ[~ Áçadää æðÁ[~|æ~
 •Á ðç ð æ ^á] ä ^Áæð^} ð æQ æq Á^} ^•^Á á[ç á] [•Áæ ð æ] .Á^@ á^Á] •[à^} ...
 çÁ •|^á~ Á^á[á!0^} ðæ @ç Á[\^} ÆÖ|Á[c^á^Á[]: ~|ç kÁÁQ æ æ ^á[Á!| á^æ^} .

- (1) Rqw'f'k'glv'elentromagneticm 'ur'f'pc . 'mgt 'qf'r qx'f'a 'ur'gek'k'nek(pcr v'f' nεr ce'k'c'v'f'0) o qqtw' gtr cf rε.
- (2) X'r 'f'cf 'xgp'v'k'xp'f' q'w'f'k'f'f' gtr cf rε' c'k'uv v'g'gr'gmt'q'k'pucnqek'r tq'k'x'k'w'r qx v'p'q'v'p'f'ej 'r qf' o 'f'p'gn'f'pc'qej t'cpw'ur'f'pc g
- (3) K'pucnq'v'g'f'p 'g'elentromagneticm 'ur'f'pc 'c'v'ε 'f'nu'q'x 'ur'f'pc 'x'o 'f'iv 'r k'o gp 'x'f'a r'gp²'o " qf" gtr cf rε.

1. 6 YndY bcghb#c dUh Yb #`d`JcVg`i nY

I dcnfb b#

- Ig'ecni | a pq'r tqxq| qxcv' gtr cf m'pc'uwej q.'rqr 0u'w' cx gp o 'xgpv'rgo 'pc'utcp 'u' p'0Lkpcnif qlf g nlr q-nq| gp' gtr cf r0J tq| q'v' fl.'fig'r q'x'eg'icni30 semxf' a ej 'l c pqw'x| plnev' a r cp'2 "
- \ nqptqmw'uo t'q'v' gp'" gtr cf r'no w'ug'q'v' gv'xg'uo tw'j qf kpxx ej 'tw k gnir k'r qj r'gf w'qf xgpv'kt' vqt'w'o qvqt'w'0R k'r qntc qx' a p'ej qf w' gtr cf r'x'qr c p'2 o 'uo tw'q'v' gp'j' tq| q'r q-nq| gp' gtr cf r'0
- X'r q' cf "ncxkceg'qf ucxvg" gtr cf m'f q' "l'gf p'2" o k'pw'f 0' Tqxp fl'pgpgej' a xglvg" gtr cf m'x'ej qf w'hf { fl'f q'u' p'x'plm'ix| f vej 0'
- X'r q' cf 'tq| r qlgp'g'gmtq magnetlen' ur qlm' "qf ucxvg'" gtr cf m'f q' "l'gf p'2" o k'pw'f . X nq'p' ur qlm' 'ug'up'q' r' k'r qntc w'p'p' 'ej qf w'u'tq| r qlgpq'w'ur qlnq'w'0'
- Mq'rf' p'v'gr m'v'p'guo q'lr gx -k' "80°C d j go 'p'cl'f'f' p'q'f ucxqx' a p'k'ej qf w' gtr cf r'0
- R gf 'ur w-v p'p' " gtr cf r' ' egr' w' cx gvg'xgpv'kt'p'c'x v'cnw'ni| co gl gp'x'qf p'j' q't' a | w' x'r t d j w'p'cl'f'f' p'p'0
- Ro| qt.'hf { fl'p'gej' a v'f'gn'f'f' qd'w'd' fig'v' gtr cf m'ug' egr' w' cx gp o 'xgpv'rgo 'pc'x v'cnw'f' qlf g' m'p' a t uw'v'gr m'q'f 'ner cnk'p' { 'wxplv' " gtr cf r'c'p' a ur'f' p'2 o w'r q-nq| gp' gtr cf r'0'
- X'r q' cf 'x r cf m'w'gr'0'gp'gti k'g' c'ej qf w'k'j p'gf 'x{r p v'g'j' r'x'p' "x{r p'c' c' cx gvg'" xgpv'kt'p'c'x v'cnw'0'
- \ nqptqmw'uo | f c'v'cnir uqd'p'p'c' gtr cf m'p'gr gu'ej w'lg'w'cp'q'xgp'q'w'x -k0' Xk' 'ut'0'16 qj r'gf p' 'o cz'0'f' q'x'q'rp'2' j q'v'cnw'0'
- Maxim' a p'q'lr qxtej qx' a "v'gr m'vc" gtr cf r' " O czlo' a p'q'v'gr m'w'r qxtej w' gtr cf r' w'l'gf p'q'v'kx ej "o qf gn 'w' a f'p' a ur'f' w'p'p' "Vcdw'm'0' Rt'q'xg v'g' qej t'cp'p' a' q'r cv gp'f'f' r' q' m'w-p'2' x -g'v'gr m'q'f 0'



Nz_Uh



Dcnfb



Dcnfb



	V^ E' a' a' a' ^	Max E [c' & @ c' A'] [c' e]
Model	(»C)	40 » C
MX-250, 251, 400, 401, 402(H), 403(H)	80	80

- J nw p'quw' gtr cf r' " J r'ef k'p'w'j n'mw' | r uqd'gp'q'w'l'gf p'q'v'kx o k'v' r { " gtr cf r' g'ri'w' a f' p' a ur'f' w'p'p' "Vcdw'm'0' Rt'q'xg v'g' q'r cv gp'f'p'c' q'ej t'cp'w'uw'ej w'x' u'q'w'ef w'u'r q' m'w-p'q'w'j r'ef k'p'q'w'j n'mw'0'



Model	MX-250, 400	MX-251, 401	MX-402(H), 403(H)
J r'ef k'p'c' j n'mw'	70 dB	75 dB	80 dB

2. P $\int df U_j U_{-c} Vg_i nY$

P $\int dg'lg'wxf gp'r quwr 'r \int tcx\{ 'nir q^a vg p^b w'pclg\}$ gtr cf $\pi'r q'lgj q'kpuvrek'pgdq$
m $\int r \nu^2 o w'wxf gp'f q'r tqxq| w'r q'f gn\{qf u^a xeg\}$ gtr cf $\pi'0$

(1) F mcf p 'x{ kv vg'xpkv gm' gtr cf $\pi'c'r qvtd\{0Rqvqo 'pcr n vg'her chpqw\}$

(2) W $\int j p \nu'$ -tqwd{ 'r $\int tw'c'kpuvrc p'$ -tqwd{ 'pc' }^a mcf p 0

(3) Rq'pcr ip p' } gtr cf $\pi'her chpqw'w| cx gvg' egre'xgpvki'pc'utcp 'x vrcm\}$
V $\int fl' nupvtqnv'g'| cx gp'\{qf x| f w- qxce\} q'xgpvkw'c'xgpvkw'pc'r tqr rcej qxce\}$ 'r qvtd\{0

(4) P^a u $\int gf p 'kj pgf 'wxf vg'f q'ej qf w'o qvqt'c'| nupvtqnv'g'ur t^a xpquv'uo tw'qv^a gp'o qvqtw0O qvqt'ug'b w'f|$
qv $\int g'v'xg'uo tw'kr m'q| pc gp^2 'pc' gtr cf rg' Mf \{ fl'lg'uo t'qrc p , o w'f'g'r tqx^2 uv\}^a o pwhkdxqrp ej$
fxqw'xqfk 'v'f' | qx $\int j q' f tqlg\}$

3. OVG'i \ U

D J'cVg'i nYdcg'hi di H'Y'X'Yb'j'Y'i j YXYb W`_fc_ .

Új È	~ \ [} Á à • ` @	P [• c]
1	<ul style="list-style-type: none"> • Qvgx g cx gvg'xgpkf0 	<ul style="list-style-type: none"> • Sce'xgpkf'qvgx gp'pcr ipq • X vc p 'xgpkf'qvgx gp'pcr ipq"
2	<ul style="list-style-type: none"> • P cr n vg" gtr cf n'her crkpw 	<ul style="list-style-type: none"> • \ nqptqnlvg'pcr ip p' gtr cf n'her crkpw0Mf { fl'pgp' pcr ip pq'her crkpw, pcr n vg'f'rg'ntqm [5] a [6] ner 0'R 'f' txc' 'mpclg'v' . Ú [Á [\ [} æ . { Á } æ] } } ðá æ ^ e' Á & ^ æ } çæ } Á ^ } çÁ
3	<ul style="list-style-type: none"> • \ nqptqnlvg'ur t' xp 'uo t'q' gp'motorw \ cr p vg'r 'kqf'gr'p'gti k'c' cug'kj pgf'x { r p vg (d j go 'l'gf p'2'ugmpf {) 	<ul style="list-style-type: none"> • Qneo flk'2' cr p'w'gr'0r tqwf w'n'lw'gf gp' gtr cf n'f'q' ej qf w'r tqx' f l'vg'r qw' g'r k'nqptqng'uo tw'q' gp' (Ur t' xp 'uo t'q' gp'o qvqt w'wnc' vlg' -kr n'pc" gtr cf ng'0\ nqptqnlvg'uo t'q' gp'xgpkf vqt w'motorw r qj r'gf go 'pc'xgpkf vqt "unt' 'nt { v'xgpkf vqt w'.) • Rq qtp 'ur'gf vlg' f c'ug' b' qvqt 'xgpkf vqt w'r qo c'w' c'j' n'f'eg'r' gucp'g'q' g'v'r q'x { r p'w'j' r'exp'j' q' x { r'pc' g. Úo: } È Sâ ^ 0Á ^ Á ^ } çá ç : Á [ç : ' Á] } ^ Á ^ : æ • çæ çá çæ çá ^ } çá [Á ç] ç Á çá [\ [ç] } [È XÁ çá [ç . { Á ç çá Á \ [} d [' w' Á ^ } ç ^ \ .
4	<ul style="list-style-type: none"> • \ cr p vg'pcr' a l'gp'c'ur wu vg" gtr cf nq. Ren'pcu'cx'vg v'cn'w'x v'cn'w'c'x vc p 'qdlgo '0 <p>D j go 'r tqxq w' gtr cf n'p'wpq'f'qf t'fl'qxc'v'p' a ur'gf w'p'x vc p'2'qdlgo { . MX-250, 251, 400, 401 : 10L/min. c'x'p'g MX-402(H), 403(H) : 20L/min.c'x'p'g</p> <ul style="list-style-type: none"> • X'r 'f'cf "automat0r qj qpwt'qxp fl'w' ex gvg'x vc p 'xgpkf' gf 'p'cl'g'v' b'a'r qo c'w'q'v'x'f'gl'v'x'g'p'k'f'3'o k'p'w'w0 <p>⚠ I dcn'cfb b'†</p> <p>BYbYW zj YH'V y'Yh YfdUX'c'X'f'Y'U_ 1 minuti 'ge n'W'U'i nUj Yb a 'j Yb'j'Ya 'bUj hU_i "</p>	<ul style="list-style-type: none"> • F q'3'o k'p'w' { r qo c'w'v'g'x'f'gl'v'x' vc p 'xgpkf'c' x { t'gi w'w'v'g'v'cn'f'w'x v'cn'w'r k'U'q'w' cup'2'o 'nqptqng'x' a p' qf g w'v'cn'qo tw'pc'ut'ep' x v'cn'w' (l'p'cn'pcu'cx'vg'r't v'q'n'r k'U'q'w' cup'2'o 'nqptqng'x' a p' qf g w'pc'r't v'q'n'qo tw0) <p>⚠ I dcn'cfb b'†</p> <p>JYb'j'c'h'j' f'Y'f' dcn'cfb 'd j'gci Ugbfa ' g'YX'c'j'z'b'f'amp'ffa Y'f'i z'U'v'm'b'Y'X'c'y'c' 'd Y'h'j'Y' b'f'a c'h'f'i 'b'U'X'a fb a 'c'h'j' Y'b'j' j' Y'b'j'i "</p>
5	<p>D j go 'ej qf w' gtr cf n'ur'gf v'lg'p' a ur'gf w'p'x f'c' gtr cf nq'p'cl'gn'p'c'r n'p'wn 'r t'ce'q'xp'f'f'g'f'ko , nqptqnlvg'r't v'q'n'qo t'c'q'x v'g' f'c' gtr cf nq'd f'f' f'rg's'p'ec'if'ine'eg.</p>	<ul style="list-style-type: none"> • Mf { fl'pgp'f'rt v'q'n'qo t. nqptqnlvg'j' qf p'q'v' v'cn'w'w'x v'cn'w' v'cn'w'pc' l'p'c' 'e'le'n't'r'ic'f'j' q'r tqwf w x j r'gf go 'n'k'q'f' r'q't'w'r q't'w'd'f'j'
<p>⚠ D j'dc'f'i y'Y'J'M'D'B H'9' j' b'Y'X'd' j' c'X'Y' "Y'b'f' [j'Y'U'n'g'h' h'y'd' † j'bi 'nz'j' U'X'm'X'Y'H'U'v' ' _m' '@_U'j'n'U'W' d'c'f'i W' .</p>		

Dcghi d'cXgHlj Ybꝛ YfdUX'U.

	S[] d[] ᲔᲟᲛᲗᲗᲟᲛᲗ ᲗᲗᲟᲛᲗ	P[• ɸ]
1	<ul style="list-style-type: none"> • Rqo caw cx gvg'xgpw pc'x vrw0 	<ul style="list-style-type: none"> • X{xctwlv'ug'p^a j rj q'w cx gp'lwqppqkf qx o 'xgpwrgo cvf 0'j tq r'q-nq gp' gtr cf n'qf 'xqf p'j q't^a w'mgt x pkn' glo²pc'wfnqwj ej 'x vrw p ej "
2	<ul style="list-style-type: none"> • X[RP VG'r q'qf "gr0pcr^a lgp'c'r gtw-g'ej qf " gtr cf n0 	<ul style="list-style-type: none"> • Rq qtp "ungf wlv'r qo ciz 'c'r n(pwz' cuvexq^a p'xgpw vqtw0 qvqtw0Mf { fl'pg.' nupwqnvlg'xpkv gni' gtr cf n0
3	<ul style="list-style-type: none"> • R k cuvexq^a p' gtr cf n'ungf wlv'p^a ungf wlv'p^a • r k'qf uvexq^a p' gtr cf n'x'ej rcf p² o 'r q cu'bo flg'f q v'ni co t pw'ner cnp { 'x" gtr cf rg'c'p^a ungf p² o w'r q-nq gp' gtr cf n0R k'ektmwcek pdgl rg 0ner cnp { 'r tqxg v'x' k-v p'xpkv mw'r tqr wej qxce'p 'r qvtd'p OF qnupcr'x { r wu v0 • \ nupwqnvlg'x { r w-v p'xg-ngt² 'ner cnp { 'r q'qf uvexgp' gtr cf n. R knt^a vnf qd² o 'qf uvexgp' 'r tqxq w'pgwo qfl w l'p'x { r w-v p'ner cnp { 'r qvilkv't^a uqx "qj q'c "cvf 0'cd { 'ner cnp "wxpkv 'pgl co t n0 • X'r q'cf 'x rcf nw'gr0rt qw'wX[RP VG'j nxp'x { r p'c 'c' cx gvg'xgpw pc'x vrw0 	

1. @ _U]nUW' dcfi W

X'r fcf 'rqtvej { 'kj pgf "X[RP VG'r f'kf "gr'ogpti k'c'r quwr wlg'f ng'p'f'g'w'xgf gp' 'cdwmf .

P[i' &@e	Ú ð } æ Á æ Á ^i] æá ^Á		Ú ð æ æ	S[] d[æá [] æ ^} ð
	ÁÁÁÁ ^Á æ ^} { ç dæ ð ^} á ^{	ÚÁ ç ç ^} { ç dæ ð ^} á ^{		
Mcr crkpc" pguqwa ^a 0		Vrcnqo t" k'vamqo gwt'wne wlf 'pww.	<ul style="list-style-type: none"> ● Ngf qucvgnir rp'f'f' xqf { ● Uvej 'ej qf . 	<ul style="list-style-type: none"> ○ \ cuvcxg" gr cf nq." f qf glvg'f qucvgnir rp'f'f'xqf { 'c'qr v tguctwlv" gr cf nq0
	D j go 'r ip p' "xqf c'kj pgf " ngupg.		<ul style="list-style-type: none"> ● Ek' f' 'a uleg'wer cnc r cyp'f'xgpvkn 	<ul style="list-style-type: none"> ○ X{ k'vkr' cyp'f'xgpvkn ○ \ nqptqnlvg' f c" ugf nq'pgp'f' cpgugpq ek' f' 'a ule'f'
	P k'qvgx gp ² o " "xgpvkn" pc'x vrcmw ug'r q'p'clg'f'vrcm up'f'f'	Tw k n'f' vrcnqo tw k'xcnwqo gtw ug'x { ej n'f' c'rg' kj pgf 'ug'xt ^a v'f' pc'pww	<ul style="list-style-type: none"> ● "X fvej 'xpln'f' uce'f'p r q'v'w'f'p' 'pgdq" v up p'f'p 0' 	<ul style="list-style-type: none"> ○ \ pqxw' nqptqnlvg x fvej qv upquv ur qlqxc'f'f' f'wd { "" pc'uce'f'p 'r q'v'w'f'p 0 ○ \ nqptqnlvg' f c'j n'f' f k'pc'uce'f'f' n'cr crkpc { p'p'f'f' o k'q 'a f'p 'p'f'f' n'f'.
	Tw k n'f' vrcnqo tw plnf { 'pguqwa pg.		<ul style="list-style-type: none"> ● P g'gr p'w^a "grgmtq/ o ci p'g'v'k' n'f' 'ur qln'f'. 	<ul style="list-style-type: none"> ○ \ o v'g'x -k'grgmtle/ n'f'j q'r tqwf w'qj ngf p " o q'f'p² j q'r g'v'f'f'p'f'f' ○ \ nqptqnlvg'pc'o q'f'p² ek' f' 'a uleg'o g' k'qd f'f' p o 'n'q'rgo "c'um'f'f'p'f'f'p 0 ○ \ nqptqnlvg' f c'o^a " p'cr v'f'f' d' f'p'q'w' j qf p'q'w'0'
Ocn "" x v'c'p " qdlgo	Tw k n'f'xcnwqo gtw wne wlg'x { uq'v'q'w hqf p'q'w.	<ul style="list-style-type: none"> ● Q'v' n'f' " gr cf n'f' r 'f'f'k-'p'f'f' n'f'0 ● gr cf nq'ug'q'v' f'f' q'rc p o 'uo tgo . 	<ul style="list-style-type: none"> ○ \ nqptqnlvg'"grgmtq/ k'p'v'c'c'k'c'motor a'r tq/ xg v'p'g' d'f' v'p² 'qr tcx { . ○ "X{o v'g'xqf k g. 	
		<ul style="list-style-type: none"> ● S'f'f'q'v'c'p² 'ek' f'f' 'a ule'f'f'c'r t' ej qf " n'cr crkpc { " blonq'x^a p0 	<ul style="list-style-type: none"> ○ Q'f'ut'c' v'g'ek' f'f' 'a uleg x'u'f'f'w'0' 	

P[i' & @e	Ú ð } æ ^ Á æ Á ! } æ á ^		Ú ð ð æ	S[] d[æa [] æ ^ } ð
	Á Ú ^ Á æ ^ } { ç dæ É } ^ } Á	Ú Á ç ^ } { ç dæ É } ^ } Á		
O cn " v æ p qdlgo		Tw k ne'xcnwgo gtw wne wlg" o lo q ^ a f p "xgmqw j qf pqw	● X'uce'p 'r qvtvd'lg x f wej .	○ \ nqptqnlvg'ucx pcuvcxgp'uce'j q'r qvtvd' c'f rg'r qv gd{ "wr tcxvg
			● Xuwr p' " a uv" ugucx{ "qd fip² j q'nqrc ver ^ pc'ek' " ^ uke'	○ Qf utc vg"ek' " ^ uke0
		Tw k n' "wcnqo tw k'xcnwgo gtw ug'x{ ej { nml'	● "Uce'p 'r qvtvd'p pgdq'v up p'p'o 'r tqpkm x f wej .	○ \ nqptqnlvg'pqr qlgp' s^ p'uce'j q'r qvtvd' a'f rg'r qv gd{ " f qv² j p vg.
	Tw k n' "wcnqo tw c'xcnwgo gtw" wne wlg" d fip² } qf pqw'.		● "Utcpc'x wcnw gtr cf n'wer ^ pc ek' p'o k' ^ ukego k	○ Qf utc vg"ek' " ^ ukeg x" gtr cf rg. ○ Qf utc vg"ek' " ^ ukeg c"qnlvg'wxpkv pqvtvd'
		Tw k ne'xcnwgo gtw wne wlg'xgmqw hqf pqw' c'p'o eq wcnqo t'wx^ f' d fipqw' j qf pqw.	● X f wej qx^ "her uc k'qf r qt'x'uce'p pqvtvd'	○ \ nqptqnlvg' f c x'uc/ e'p'o 'pqvtvd'pgx{ p'k^ p mgt "lgj q'Augn'c r tq/ xg vg'pwp^ "qr cv gp'
		Tw k ne'wcnqo tw wne wlg'x{uqnlw j qf pqw' c'p'o eq xcnwgo gtw" wx^ f' d fipqw j qf pqw.	● ^ uv'Augmw'x wæ p² j q r qvtvd' r uqdwlg qf r qt.'r qr 0uv³ xcl'p' f qr tcxp'x -ne'pgdq lg' r v^ w'r "hk-x{uqnl'.	○ \ nqptqnlvg'umwq pqw f qr t0x -nw'c' v^ w w'x wæ p² j q'r qvtvd' c'r tqxg vg'p'gl d{ v^ " qr cv gp'
	Tw k ne'wcnqo tw wne wlg'p' nqw' j qf pqw' c'tw k ne" xcnwgo gtw'wne wlg" o lo q ^ a f p " p' nqw' j qf pqw.	Tw k ne'wcnqo tw k'xcnwgo gtw wne wlg'p' nqw j qf pqw.	● Qrc p "uo t" qv² gp'	○ \ co vg'xqf k g.

P[!~&@e	Ú ð } æ ^ Á æ Á ^] æ á ^		Ú ð á æ	S[] d[æ a [] æ ^ } ð
	Ú ^ Á æ ^ } { ç d æ ð ^ } á ^ {	Ú Á ç ^ } { ç d æ ð ^ } á ^ {		
Motor ug r gj 'k ^a .			<ul style="list-style-type: none"> ● P q n r "per v ● R g v f l g p 	<ul style="list-style-type: none"> ○ \ n q p t q n l v g " f c " p e r v c " n o k q g v " q f r q x f c l q ○ \ n q p t q n l v g " f c " o t p ^a j o q p q u v c visn q k c " n e r c r k p { l g " q f r q x f c l q ○ \ c l k u v v g " f q n q p e r g l - v t ^a p
X v e p o d l g o " p ^a j r g m g u n		T w k n e " x a m i q o g t w w n e v l g " x { u q n q w j q f p q w .	<ul style="list-style-type: none"> ● S q q " l g " w e r c p ² " e k " p k " ^a u l e g o k 	<ul style="list-style-type: none"> ○ Q f u t c v g " e k q ^a u l e g .
g t r c f n q u g ' e j x l g 0			<ul style="list-style-type: none"> ● X c f p ² " ^a m e f { . ● X q p " n q v x p - t q w d 0 ● \ c x g p ² " u c e r q t w d q 0 M c x k c e g . ● " Q r q v g d g p p g d q " t q v / x g p n q f l k u n e " g t r c f n . ● " R q - n q g p " r r f - " g r g m t q / " o c i p g w p g d q " x g v p q . ● M q f r " f y n a m i c n f " t q x / p q x ^a j c " u g u v e x { " j p c e j q g r g m t q o c i p g w . ● Q d f l p ² " n q n q " a / p g d q r r f - " g r g m t q o c i p g w l g " x " n q p e n w u " r g x p q w " ^a u v ● Q r q v g d 0 n q f l k u n q " o q v t w 0 	<ul style="list-style-type: none"> ○ Q r v p " k p u e n l v g . ○ F q v j p v g " - t q w d { . ○ X { k u v v g " c " q f u t c v g r k p w ' e j x p 0 ○ R t q x g v g " x o p w ○ R t q x g v g " x o p w ○ Q f u t c v g " r k p w " p g d q p c j t c v g " p q x o . ○ " R t q x g v g " x o p w ○ " X { o v g " n q f l k u n e " p g d q " o o t o r .

''2''i XfyVUU_cbf`U

⚠ J U f c j z b †

Dci yj Yh'cgcVbfcW fUbbf`dfUWtj b†dfcgh YX_m

R kr 'p 2 o 'nqpvcmw'u'pgdg| r g p o k'ner crkpc k'lcnu'luqw'ej go lenz 'ner crkpc{ .f'qej a | 'r k'f'qv'mw'pgdq'r k'tq| uv 'm' pww'ner crkpc{ 'n'iqj tqf'gp'q' 'c'r qnq'fm' 0R kr t' a ek' qw'f'k'gl'v'QQRR (maskc, qej tcpp2 'dt rg.'t'w'nc'k'eg'c'v' 0

JMDB H9`d j cX'Y''YbYf[]Y'

X{ xctw'lg'ug'Àc| w'gr0r tqwf go 'v'p . 'flg'X[RP GVG'gr'f'pcr a lgp'q'ni'qf u'cx'gp'q' gtr cf m'c' c 'q' gp'q'r kr t' a ek'pc' c 'q' gp'q'

● DYbbf`cbf`m

- (1) \ nqpvcmw'v upquv'ner crkpc{ 'x" gtr cf r'g'r gf 'ur w-v p'p " gtr cf m'0R k' l'k-v p'p'p'gv upquv'k'lg' cni' | a pq'w'x' f v' gtr cf m'f'q'r tqxq| w0
- (2) \ nqpvcmw'g'r n' pwn 'ej qf " gtr cf m'd'gl ' | p' a o gni'cdp'qto a m'p'j q'j m'w'w'c'x'k'dt'ce'p'0
- (3) \ nqpvcmw'g'j r'f' l'p'w'ner crkpc{ 'x'uce'p'f'f'f'c'v'nc'p'c'ut'cp 'u' p'p'0
- (4) Rqt'x'p'gl'v'v'nc'w'x v'nc'w'c'g'rg'm't'k'em 'r' tqwf w'p'co gp 'd j go 'r' tqxq| w'u'j qf p'q'w'o k'w'x' f p o k'pc" v' r' q'x'2'o "v'w'w'o q'q't'w'm'iq'x gp'q'f' r' q'x'f' c' l'p'p'q' | a v' flg" gtr cf m'0
* Rq| qt.'j qf p'q'v' 'w'x' f p'2'pc'v'nc'w'o t'w'lu'w'w'Ào t'p'2'o t'p'2'j o q'v'p'q'v'k'f'c'p'2'ner crkpc{ 0M'q'j q'w'v'nc'w'o t'w'p'gdq x'c'm'w'o g'w'w'o w'f'f'd v'x'q'v'x gp'2'r'q'ni' g'r'q'w'g'd j go 'r' tqx'x' f p'p'o gp'q'0R'q'w'ni'p gp'q'nc'f'f'2'j q' b' gp'q' o w'f'f'g' m'q'j q'w' c'x 'f'0M'f{ f'f' | u'c'p'g'ni'q' q'w'q'v'x gp 'k' c'ej qf w' gtr cf m.'pc'o 'p'p'o ge'j c'p'k'uo w'u o flg'r u'q'd'k' o l'o q' a f'p 'v'nc'm' r u'q'd'gp 'x'q'f'p'p' 't' a | go 0
- (5) Mf{ f'f'o a v'g'r k' r' t'cx'gp'2' | a m'f'p'q' gtr cf m.'qd cu'v'q'v'p'cl'g v'g'ni'lg' q'w'ej q'x' a p'q'x'g'u'c'x'w'v'x'c'f' r' k' r' t'cx'ep'q'w'k'0
- (6) \ nqpvcmw'g' f'c' | c'ej qf w' gtr cf m.'p'g'ni'f'f'f' v'nc'w'x v'nc'w'r't v'ni'w'x v'nc'w'c'p'c'r a l'ge'p'p'c'r v'f' b' q'q't'w'0 X'r 'f' c'f . 'flg'p'c'w'c'p'g' | p'c p'2'ni'q'f'f'f' p'p'p' m'g't'2' | 'w'x'g'f' gp ej 'j qf p'q'v.'r qu'w'r w'lg'f' r'g'p' a x'q'f' w'N'q'nc'r'k' c'eg'r' q't'w'ej " m'q'f' u't'cp p'q' | a x'c'f' | c 'q' gp'q'0

● PfUj]XY'bf`_cbf`m

M| clk-v p'q'x nqpp'2'j q'c'j r'f' n'j q'ej qf w' gtr cf m.'lg'p'w'p'2' r' tqx'x' f v' r' t'cx'k'f' gp'2' nqpvcmw' f' r'g'p'f'f'g'w'x'g'f' gp'2'j q' r' qu'w'r w'0 R k'f' go q'p'v' f'k' gtr cf m.'| c'ej a | g'v'g'q'r'c'w'p 'u'v'g'e'p' k'u'q'w a u'w'nc'o k'c'd{ 'p'g'f'q-m'ni'lg'k'ej 'r' q-n'q| gp'q'0 Rq| qt'pc'p'gdg| r g 'r' k'um'f'f'p'w'f'f'r' t'uv . 'p'gdq 'j p'c'e'f'f'g'rg'm't'q'o c'i p'g'v'c'lg'j q'r'f'f' - 'o c'f'f' | p'c p'q'w'o c'i p'g'v'nc'w'v'f'f'w'0

Qc\çaa[] d[] A	S[] d[] } Å ð cæ	Uâ•dæ } Å çaa^
Mçflf ej '6 m uflp 0 * P wppq'x²u' \ ^ pco { 'nqpvqtqf0	<p>J pceflmagnet0gf p0</p> <ul style="list-style-type: none"> ● R flqo pquv'nmw p ej 't j ? ● J pceflmagnet urtª xp 'wej { egp? Xqrp '8j tcp0vcx efl-tqvd? ● Luqwxpkv 0qdxqf 'grgmtqo ci pgw a'j fl grbo qqt w'uqvuq²? (o ax. ezcentricitc: 1/10 mm) 	<ul style="list-style-type: none"> ○ Mqpvcmwlv'xc-gj q'r tqf gleg lkuwflg/rik'ª xcf w ○ J pceflmagnet"ª fp 'wej { vg. Wp j p vg'vcx efl-tqvd. ○ Urª xp 'f qvª j p vg'vcx efl-tqvd pgdq'x { o vg j pceflmagnet.*R k x o p 'nqpvcmwlv'r tqf gleg.)
	<p>\ cf pflumfl</p> <ul style="list-style-type: none"> ● R flqo pquv'nmw p ej 't j 'xg xtª pfl? ● Vtj rkpml 'pc'nqpeqx²"ª uk ner cflp { ? ● Qr qv gdgp fl cf pflr flrcmª ● Qr qv gdgp fl x gvgpc. ● Snxtp { 'x' cf pflumflpk 	<ul style="list-style-type: none"> ○ Mqpvcmwlv'xc-gj q'r tqf gleg lkuwflg/rik'ª xcf w0 ○ X { o vg' cf pflumfl 'r k' lkv pfl ª xcf { . ○ Montamwlv'r tqf gleg'r k lkv pflª xcf { . ○ X { o vg'r q'f qucflegpfl f qxqr0qr qv0 ○ X { kuv vg.
	<p>Rrfl - 'grgmtqo ci pg</p> <ul style="list-style-type: none"> ● R flqo pquv'nmw p ej 't j 'x' cf pflª uk'pgdq'xª reqx²o " v rgug? ● Vtj rkpml 'x'r t { umfl lek' cf pflª uk pgdq'xª reqx²o "v rgug"? ● Qr qv gdgp² 'nqflkunq. (\ o vg tq o t { .) ● Ucx'qd flp² j q'nqnr'wej { egp² j q nlr fl -k'grgmtqo ci pgw' 	<ul style="list-style-type: none"> ○ Mqpvcmwlv'xc-gj q'r tqf gleg" lkuwflg/rik'ª xcf w0 ○ Mqpvcmwlv'xc-gj q'r tqf gleg lkuwflg/rik'ª xcf w0 ○ X { o vg'r q'f qucflegpfl f qxqr0qr qv0 ○ X { o vg'pgdq'nqpvcmwlv'r tq/ f gleg'lg/rik'wej { egp'xqp² .
	<p>Qd flp² 'nqnrq</p> <ul style="list-style-type: none"> ● Qr qv gdgp "Àwpfl'ntqwfngmª o vg'tq o t { .) ● R flqo pquv'tj rkpml? ● Snxtp { 'pgdq'wera pfl'wvplv qd flp² j q'nqnr. ● Tq o tqxª " o pc x'qd flp² o nqrg. 	<ul style="list-style-type: none"> ○ X { o vg'r q'f qucflegpfl f qxqr0qr qv0 ○ X { o vg'r k' lkv pflª xcf { . ○ X { kuv vg0 ○ X { o vg'r k' lkv pflª xcf { .
	<p>R gf pflumfl</p> <ul style="list-style-type: none"> ● Snxtp { 'x'nqpvcmpl'ª uk'u'ner cfl0 ● R flqo pquv'tj rkpml? ● \ pª o ml 'qr qv gdgp fl nmw p² 't j { , t j { 'x'ntqwflnw'r fl -v ? ● Tq vflgp 'pgdq'r tcumm O/ntqwfngm ● Mmw p² 't j { 'x'pgl x { mlª o o fluv . 	<ul style="list-style-type: none"> ○ X { kuv vg0 ○ X { o vg'r k' lkv pflª xcf { . ○ Mqpvcmwlv'r tqf gleg'r k lkv pflª xcf { . ○ P cj tc vg'O/ntqwfngnlg/rik' tq -fl gp'pgdq'r tcumm 0' ○ Mqpvcmwlv'xc-gj q'r tqf gleg" r k' lkv pflª xcf { .
	<p>X gvgpq</p> <ul style="list-style-type: none"> ● R flqo pquv'tj rkpml? ● Qr qv gdgp fl v ge'fej "ª ufl 	<ul style="list-style-type: none"> ○ X { o vg'r k' lkv pflª xcf { . ○ X { o vg'r q'f qxqr0qr qv gdgpfl

● 8 c j c`Yb f`cdch YVYb f`c y j g_ U U j Y h Y b U

R`a} [d æ mm

Model	MX-250, 251, 400, 401		MX-402, 402(H), 403, 403(H)	
	Ú[â[âi } ð	XÁ[à Á ç { } ^	Ú[â[âi } ð	XÁ[à Á ç { } ^
Xp k v p`r t o t n j f l k u e	18	19	24	25
Xp l`r t o t x g v g p c	18	17	24	23

* Mf { fl`tq| f`h`b`o`g| k`x`p`k`v`p`r`o`t`o`t`g`o`n`j`f`l`k`u`e` } (Ú21 | "qdt0pc`ut035) a`x`p`l`r`o`t`o`t`g`o`x`g`v`g`p`c`
(Ú20 | "qdt0pc`ut035) r`g`n`g` Ú1 mm, p`w`p`q`r`t`q`x`2`u`v`x` o` p`w`d`w`n`j`f`l`k`u`e` (l`c`n`q`r`f` – "g`r`g`m`t`q`o`c`i`p`g`w` Ú8
| "qdt0pc`ut035) p`g`d`q`x`g`v`g`p`c`r`q`f`n`g`v`q`j`q`n`f`g`l`g`x`v`q`r`q`v`g`d`g`p`d`g`l`"q`j`n`g`f`w`p`c`j`q`f`p`q`v`x`g`x` –g`w`x`g`f`g`p`2`V`c`d`w`r`e`g`0
X`r`f`c`f`"g`r`c`f`n`v`r`w`AV`k`A`E` (MX-250 c`f`l`401) "u`g`x`g`v`g`p`c`n`j`f`l`k`u`e`" (l`c`n`q`r`f` – "g`r`g`m`t`q`o`c`i`p`g`w` Ú8)
o`w`u`f`p`c`j`t`c`f`k`u`q`w`c`u`p`0`

* X`r`t`x`e`j`h`f`|`f`e`j`r`t`q`x`q`l`w`u`g`b`o`f`l`g`q`d`l`g`x`k`v`r`q`a`v`g`p`q`r`q`v`g`d`g`p`r`q`u`w`x`p`e`j`"a`u`f`T`q`v`l`g`d`f`l`p`2`.

● 8 c j c`Yb f`cdch YVYb f`g h b f`c`_f c i y`_i

R`a} [d æ mm

Model	MX-250, 251, 400, 401, 402(H), 403(H)
T`n`q`w`n`e`x`f`q`d`f`q`f`a`p`f`	8
T`n`q`w`n`e`x`f`q`d`x`o`p`f`	6

* "U`w`r`g`"o`g`l`k`r`n`e`j`q`w`À`u`p`f`j`q`n`t`q`w`f`l`w`" (Ú22 | "qdt0pc`ut035) a`q`d`f`l`p`o`n`h`u`r`g`o` (Ú8 | "qdt0pc`ut057+
r`k`f`q`f`a`p`f`l`p`f`2`mm` (3`mm`w`MX-250). F`q`x`q`r`g`p`2`j`q`q`r`q`v`g`d`g`p`À`u`p`f`j`q`n`t`q`w`f`l`w`l`g`f`q`u`c`f`l`e`p`q`n`f`{`f`l`u`g`v`g`p`v`q`
u`w`r`g`"u`p`f`f`p`c`2`mm. R`e`n`b`o`w`u`f`l`g`r`t`q`x`2`u`v`x`o`p`w`q`d`f`l`p`2`j`q`n`h`u`r`c`u`À`u`p`f`o`n`t`q`w`f`l`g`o`0`

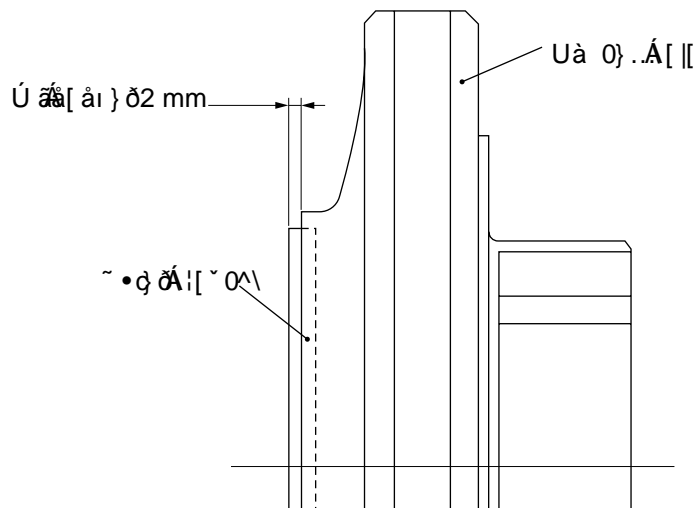

3. 'Bzl fUXb#Xf#m

Rtcxkf grp^a x o pc'p f#uw-p ej 'p^a j tcf p#ej 'f#h 'lg' a tw#qwf r#vj qf qd² j q'dgl r qtvej qx² j q'r tqxql w' gtr cf r#OX o pw' p^a urgf w#p#ej 'ur qv gdp#ej 'f#h 'r tqx^a f l#g'xg'ucp#xgp ej 'lpvgtxcrgej 'x' uqwr#f w#p#f#g'w#gf gpqw'vcdw#q#w'c'f r#g'lg'f#j q p^a urgf p² j q'h#qo gp^v g0

Q#u0P1: ^c#A[~ i#d^	Q#e'ic#e# { }^	S5#A[~ i#e'#A							
		MX-250	MX-251	MX-400	MX-401	MX-402	MX-403	MX-402H	MX-403H
1 U#u#xc'r' gf0m#p	10,000 hof lp	MX0109		MX0125	MX0131	MX0174		MX0188	
2''' U#u#xc'qd f#h#q#60Hz		MX0111	MX0120	MX0127	MX0133	MX0176	MX0184	MX0190	MX0191
29'' U#u#xc'qd f#h#q#60Hz		MX0112	MX0121	MX0128	MX0134	MX0177	MX0185	MX0185	MX0176
8 U#u#xc'r'f# -v' g#o ci p0 C (w#j r#h#r#)		MX0113	MX0122	MX0113	MX0122	MX0178	MX0186	MX0178	MX0186
8 U#u#xc'r'f# -v' g#o ci 0 R (PTFE)		MX0114	MX0123	MX0114	MX0123	MX0179	MX0187	MX0179	MX0187
8 U#u#xc'r'f# -v' g#o ci p0 A (ngtco len#j r#p#h#x?)		MX0115	MX0124	MX0115	MX0124	—	—	—	—
23 O/ntq#wl#m(r tq'um#)	10,000 hof lp'pgdq'r kn#ff ² f go qp ^v fl# gtr cf r#.	MX0116		MX0129	MX0116	MX0180			
20 X g#p#q	10,000 hof lp	MX0118				MX0182			
19 \ cf p#r' f#rcm		MX0119				MX0183			

Rq| p0B: uq#w^a u#n#q# 'm#f'Q/ntq#wl#w'lg'r tq'v'r 'X' (FKM).

X'f#f q#u#k#w' r#p p² 'w#p#-f#h#to { 'w#x^a f l#g'v'r 'E (EPDM) a'v'r A (Aflas[®]).

Ro| p0L: x -g'w#gf gp 'lpvgtxcr#x o p{ 'r g#r q#m#f^a " gtr^a p#l' ku^v 'x#f { 'r k'q#m#p#l'v#r r#v 0'lpvgtxcr#x o p{ 'l^a x#l#l' pc'x#r#p#q#u#gej , ter r#v 'c'f cn#ej 'r qf o 'p#n#ej " gtr cp² 'n#r cr#p{.

Ro| p0B: N#q#l#u#q" #u021 (w'r f# -v' g#r#m#t#qo ci pgw' #u08), 'A#v#p#l'ntq#wl#m' #u022 (w'ug#v#x{ "qd f#p² j q'h#q#r" #u029) c'x g#p#q" #u042'ug'b p#l' r q'f q#u#f#p#l'f q#x#q#p² j q'q#r qv gdp#l'c#n#w#gf gp#p#e'ut034 dgl 'q#j r#f w#p#l'p#vgtxcr#x o p{ " xg'x -g'w#gf gp² 'vcdw#e#g0

MX-250/251/400/401

MX-402/403/402H/403H

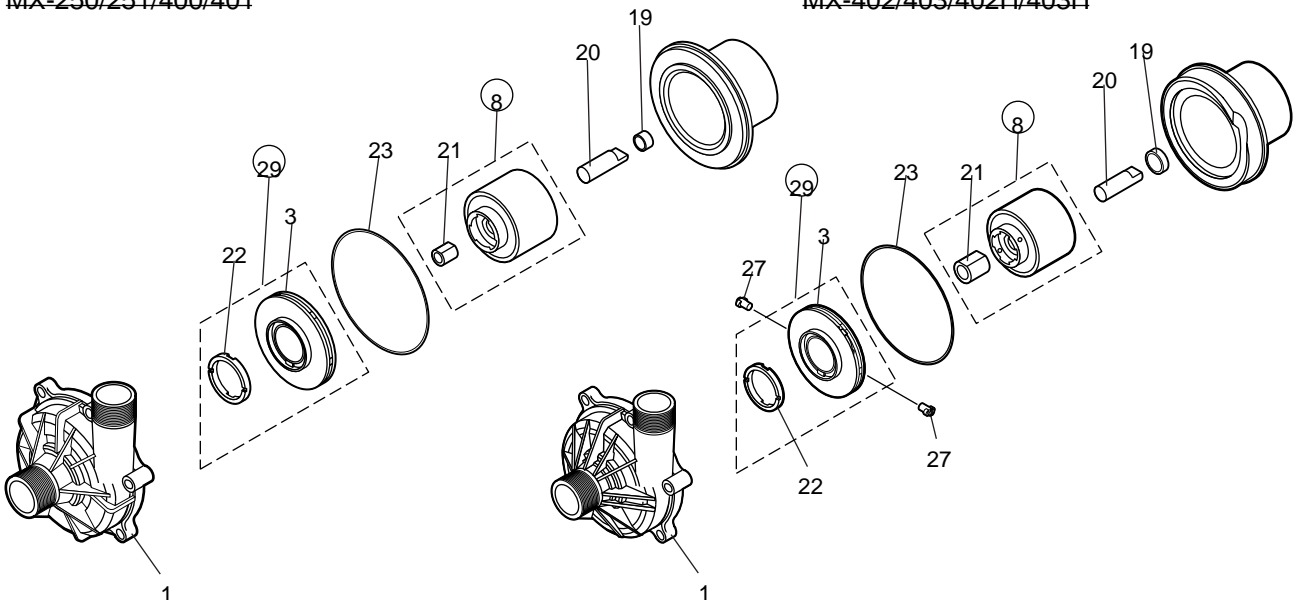

4. D Yä'čbłży' Ua cblży'

⚠ JUfcj zbz

Dci ýj Y'ñ'cgcVbřcW fUbbf' dfUWtj břdfcgh YX_m

R kř 'p 2 o 'nqpvcmw'u'pgdg| r g p o k'ner cřpco k'lcni'luqwej go lenř 'ner cřp{.'f qej a | r k'f qv(mw'pgdq'r křq| uv knw ner cřp{ 'nřj tqfłp'q r c'r qnřfm(0R kř t a ekř qwf'kglv'QQR'no cunc.'qej tcpp2 'dt rg.'twncxleg'cvf 0

JMDB H9'd j cX'Y''YbYf[JY'

X{xctwłvg'ug'Àc| w'gr0r tqwf go 'řp . 'flg'X[RP GVG'grřpcr a lgp'niqf uwxgp' gtr cf n'r kř t a ek'pc' c r gp'0

6 YndY bcglbřcdUh Ybřd J'XYa cblży]Ua cblżyř YfdUXU

- * Rq'x{lo w'p'cra lge'ej 'xqf k 'qf' o qvtw'q| pc vg'v' v'lgf pqvka2 'xqf k g'ni| clk-v p'lglej 'qr v2 j q'ur t a xp2 j q' | cr qlgp' řb fl'ug'x{xctwłvg'qr c p2 j q'qř gp' o qvtw'r q' | pqxw' cr qlgp' xqf k 0'
- * Ig' | cni | a pq'f go qpvcv' gtr cf ni'pcf 't a o ge'wx a f p 'x'vqo v' o cpwř n0'
- * R gf ' | cj a lgp' ř 'r tce' || egr'w' cx gv'xgp'vni' 'pc'utcp 'u a p'c'x vcmw'c'x{ kuv vg'xpkv gni' gtr cf n0
- * Grgmtqo ci pgleni 'u'ř'r uqd'ř'wxpkv" gtr cf n'lg'x{uqni 0Pq| qt'pc'pgdg| r g r' kum'ř pww'ř tuv 'd j go 'f go qpř flg k'o qpř flg' gtr cf n0F dglv.'cd{ 'ug'pc'grgmtqo ci pgl' pgr kcj qxcni' flgrę p2 " a ułeg'r tcej w0
- * 'P gr qpgej a xglv'grgmtqpleni | c r gp' pgunw w'ř'ug'u'magneticm o 'r qrgo 'x'dni' nqwk'grgmtqo ci pglv .

4.1 DYa cblzÿ

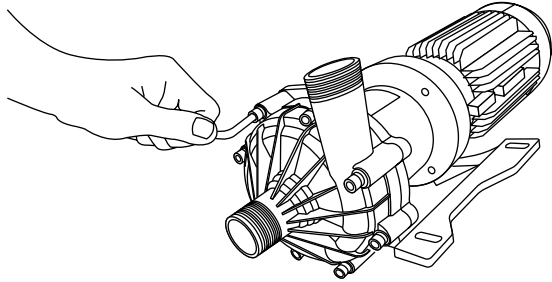

- 1) Qf utc vg"-tqwd{ 'u"-gułj tcppqw'j rxxqw' a x{lo vg r gf p'um' | 'f tff mw'bo qvqtw0\ g'um'p 'x{rt' | fp vg | d{vuxqw'her cłpw'c'um' | 'x{ kuv vg0

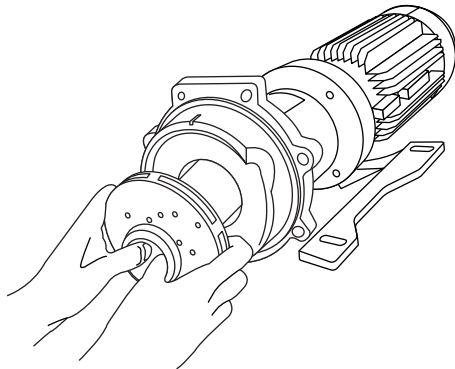

- 2) X{uw vg'qd fp' hqmq'u'r rñ -v o "grgmtqo ci pgw0Rq| qt pc'pgdgl r g 'r kum' p'w' r tuv 'w'twnq'w0

- 3) R k'x{1'p' a p'qd fp'j q'hqrc' | 'r rñ -v "grgmtqo ci pgw r quwr wlv'f rg'p'fg'wxgf gp'j q'p' xqf w0Rq| qt "pc ngdgl r g 'r q-nt' d' p'lw'w' a uv'0

a. X'r 'f cf "MX-250-401

Wëj qr vg'r rñ - 'f q'twn' 'c'rgj eg'r qmrg g'lv'r r'w'lem o mcf 'kngo 'pc' | cf p' | a uv'qd fp'j q'hqrc' n'wupcf p p'lgj q' x{lo w' | 'r rñ -v "grgmtqo ci pgw0Mf {fl'pg' g'x{uwpqw," p'gucfvg'ug'q'v'ukqw.'crg'x'nfvg'f'q'j qtn' xqf { 'q'q'q'; 2Æ+' pc'f'qdw'r v'k'o k'p'w0 Rq| qt 'pc'pgdgl r g 'r qr' a r'p' r tuv " w'twnq'w'x'j qtn' xqf 0

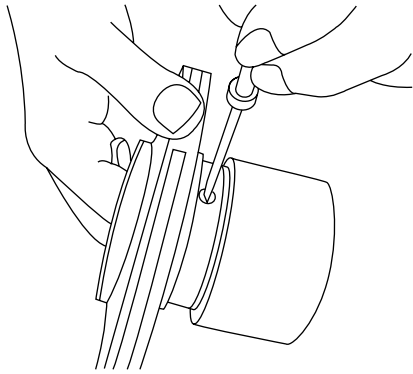

b. X'r ¶f cf "MX-402(H) a 403(H)

Qv' glv'r qlkuvnw'r tqv'uo tw'j qf kpx ej 'tw k gm q'; 2'uvw'r qo qe¶'o cfr'j q"-tqwdqx^a mw'c'r cm lk' cwx vg'f qxpkv 0Lf g/rk'v fnq'x { wx k'xgp.'rgj eg'r q/mgr glv'pc'nupge'twnq'lgv'k'-tqwdqx^a mw0Mf { fl'pgn' g"-tqwdqx^a nlr qwf¶'v'hx rk'r q-nq| gp² 'f t^a fle'g'pc'r qlkuv'eg, qv' glv'r qlkuvnw'w| gxpkv 'r n' -v "grgmtqo ci pgw' r qo qe¶'-gukj tcpp² j q'm¶| g0X'vqo vq'r ¶f cf 'o wu¶|g qv' gv'm¶| go 'xg'uo tw'j qf kpx ej 'tw k gm R kq^v gp¶| x'qr c p² o 'uo tw'ug'r qlkuv'nc'r q-nq| ¶0Rq'qvq gp¶|r qlkuvnw'w wq'x { wx vg'xgp' | 'xp l-mw'r qo qe¶| v' lpm' 'cr qf 0

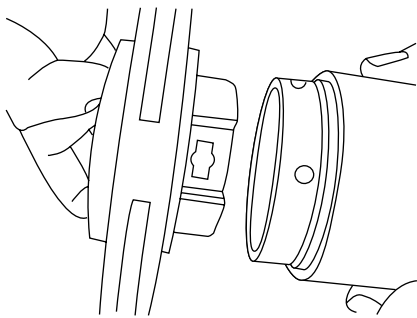
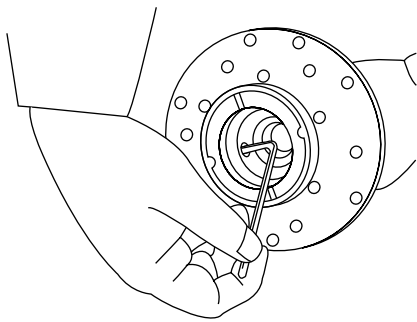

Rq'qf utcp p¶|qdqw'r qlkuv'gm'x { lo vg'qd flp² 'nq¶| | 'r n' -v "grgmtqo ci pgw'rgj m o 'r qm'gr^a p¶|o 'r r'uv'le/ m o 'mrc'¶k'ngo 'r q'qdxqf w'qd flp² j q'nq'rc0P glf g/rk x { lo qw.'r qpq vg'pc'r v'o kpw'f q'j qtn' xqf { *cuk'; 2A+c'x { uw vg'rgj m o 'r qm'gr^a p¶|o 'lcm' wxgf gpq'x -g0Rq| qt'pc'pgdg| r g ¶| r qr^a rgp¶|0

Dg| 'qf utcp p¶|r qlkuv'nc' 'pgn' g'qd flp² 'nq¶|q'f f rks'qf r n' -v "grgmtqo ci pgw'0Rqwf'k'¶|o 'u'¶|n' 'n'ix { lo w¶|qd flp² j q' nq'rc' | r uqd¶|vg'r q-nq| gp¶|f ¶|n 0'

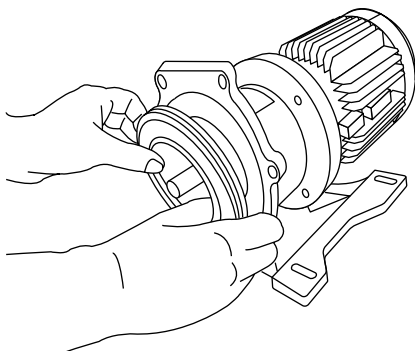

- 4) R k'x { l¶|o^a p¶| cf p¶|lum¶|p ' | cuw vg'bo cn "-tqwdqx^a m f q'qdxqf w' cf p¶|lum¶|p 'c'rgj eg' cwx vg"-tqwdqx^a ngo f qr g'w Pq| qt.'cd { 'pgf q-nq' n'ix { wx gp¶|t j { 'pc'" 2/mtqwf'lmv0

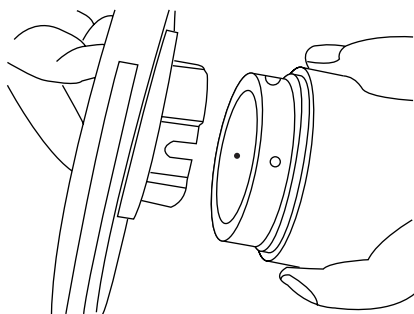
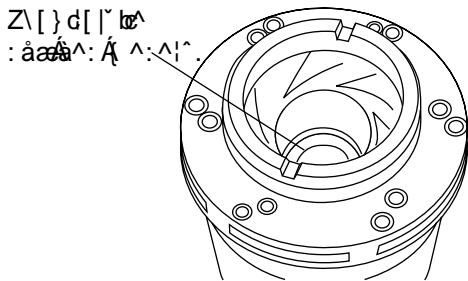
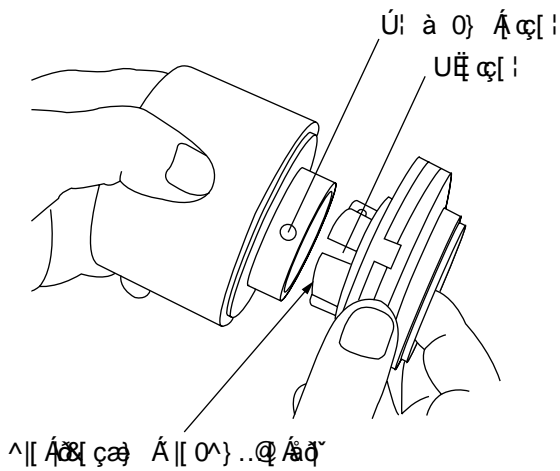

4.2 Acblzÿ

1) O qp   fl'qd flp2j q'n  r'f q'r n   -v 'grnmtqo ci pgw
a. X'r    cf "MX-250-401.

Uguc vg'nluqd "x{uqvr n'c' cr w-v p2" a u  r n   -v
grnmtqo ci pgw'c'qd flp2j q'n  r'c' cvx vg'qd flp2
n  r'f q'ur qf m   P    0c^  [      :    }       : ..{
}    | z   \    d {    } ^c    UË    :          : ..{
\[\                :       \       :       |         
            :       :       :       : }       |
d          :       |       :]    }    |    : ..         
   | z   \    d {    } ^c    E   { fl'ug n'  qxc p2 'wqflgp'   
ngfc    r tqx2 uv'pgr qwf                'cng'          r n   -
grnmtqo ci pgw'lj q'r qpq gp'   'f q'j qtn' xqf { (q  r
; 2   +r q'f qdwr          X{ xctwvg'ug'pgdgl rg   
r qr a rgp'   r tuv 'x'j qtn' xqf 0

b. X'r    cf "MX-402(H) a" 403(H)

U   qxc p 'f    r n   -v 'grnmtqo ci pgw'   a 'f xc'qwxqt { .
| 'plej fl'x v'      r tq' r qlk  w (stwr qxkv 'u'xp l-  
rt o tgo '8'bo o 'c'xpkv p'   12 mm) a'o gp-   qwxqt (3
mm rt o t) rtq'    gn' 'ej n' gp'   U-qwxqt qd flp2j q
n  r'c'bo gp-   qwxqt (rt o t'3 mm) r n   -v 'grnmtqo ci /
pgw'urqwf'   r tq'    gn' 'ej n' gp'   Xn   f glvg'qd flp2' n  r
r qo c  f q'r n   -v 'grnmtqo ci pgw'cd { 'ug'qdc'qwxqt {
pcx| a lgo 'nt { n' . lg /rk'xmi f a p'   qd'   flp 'r tqxgf k  p2.
pcj glvg' r n   -v 'grnmtqo ci pgw' r qw' g'j qtnq'w'xqf qw
'q  r' ; 2   +r q'f qdwr         

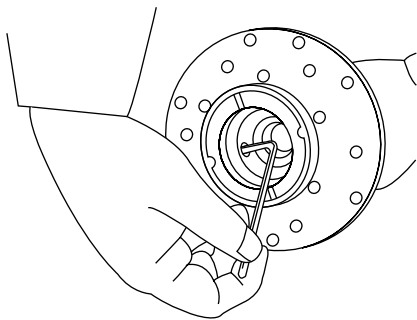
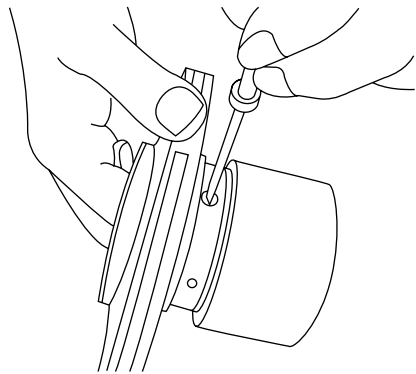
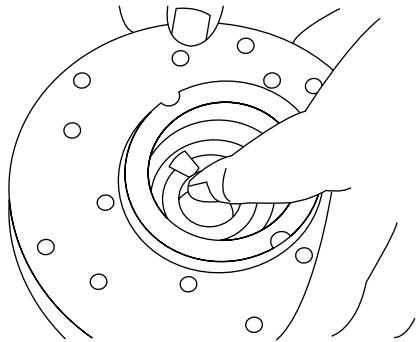

Rq'xmqfegp'qd flp² j q'hqre (rfexcp 'wqfegp² j q+'xmqfvg" r qlkumw'nir tx² o w'uwv pk' 'xpkv mw'c'r qvqo 'lk'r gxp vej qr vg'r tuxgo 'l 'xpkv mw'c'w' j p vg'qv' gp'p xg'uo tw'j qf kpx ej 'tw k gn'q'90 uwr 'l 'xp l-¶ utcp{ 'r qo qe'¶'o c'f j q'-tqwdqx^a mw0Mf { fl'g'r qlkumc" r gxp 'l clk-v pc.'r qe'¶'g'lg'¶'¶ cumq gp'¶' Qd 'r qlkumf" pco qpwlvg'x'uwv tp² 'r qm' g.

X'r ¶' cf . 'flg'f t^a flne'r tq'o cn "-tqwdqx^a n'lg'r q-nq' gp^a c'pgr g'lkr qwf'¶'¶' h' g'r qlkumw'pco qpvxev' 'xpkv mw r qo qe'¶'-gukj tcpp² j q'm¶' mw' 4mm. Rq' qt.'qv' glvg m¶' ngo 'r tqv'uo tw'j qf kpx ej 'tw k gm Q^v gp'p x'qr c p² o 'uo tw'j tq' ¶'r q-nq' gp'¶'r qlkumf 0

- 2) Xnif glvg'r qo cwr' n' - 'grgntqo ci pgw'u'qd flp o 'nqrgo " 'f q' cf p'¶'um'p . \ nqvtqmw'g' f c'p'gluqw'pc'r n' -x'ku'grgntq/ o ci pgvgo 'vej { egp{ 'flgr' p² 'nqumw'f 'c'lkp²'ek' ¶' ' a uvkg0
- 3) P co qpwlvg' cf p'¶'um'¶' 'u'r n' -v o 'grgntqo ci pgw'ng nq'p' qrg0

⚠ I dcnfb b¶

Dcnfb' bUd ¶ca bcghj Y_f'a agnet]W_f' g¶m' J`c'yt' d'Ugh]W_f'bYVc`X Yj bf'fcnd fma Yn]nUXb¶g_ ¶ ` U_cbc`YVfzb]¶g_ ¶bi h¶dfgh "

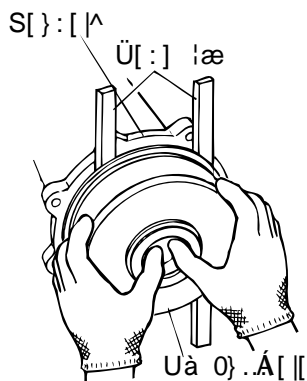

4) R kuřfvg O/ntqwfgn' nř gf p'um'pk \ nřvtqnlvg' f c'pc'p o 'pgp'ř tcej 'pgdq't j c. P guo 'řg' cr go gpqw' 2/ntqwfgn'xřfks0Q/ntqwfgn'pguo 'řd v'x{řgr v'p' nřwupwř0VÁ [á^| ÁMX-250, 251 a 401Á^•æ e'Á^ ài } Áæç •c] ^\ Áæ} Á\ ð Áæ^ á} Á\ ð Á^ á^0Á&@& b'e'Á^ á} Á\ ð ÁÁæ} Á\ ð ÁÁ Öç Á^ ài } Áæ} Á\ ð Áæçæç •c] ^\ Áæ^ á} Á\ ð Á [~ Á Á [á^| MX-402(H) a 403(H).

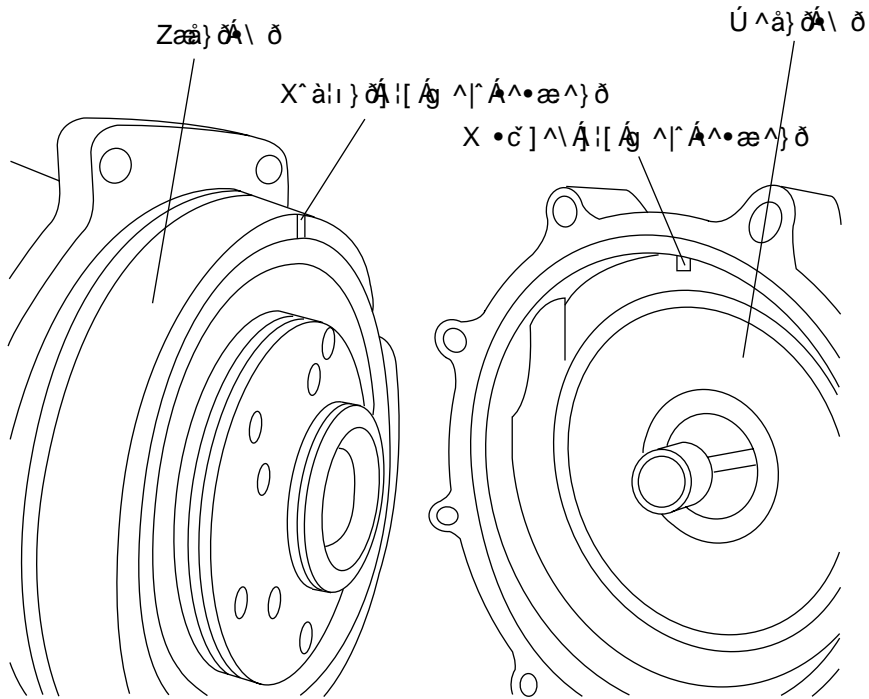

5) P co qpwlvg'r gf p'um' 'ng'nřp| qřg'o qvqtw
 –j nřř 'řp . 'řxpqo tp 'w'j p vg'Áej {v'p''-tqwd{. P 'řg'luqw'wxgf gp{ 'o go gpv' 'wcfřp'0

Model	T [{ ^} Áæ^ } Á: [~ á
MX-250,251, 400, 401	11.8 N·m
MX-402, 402(H), 403, 403(H)	14.7 N·m



IWAKI CO.,LTD. 6-6 Kanda-Sudacho 2-chome Chiyoda-ku Tokyo 101-8558 Japan

TEL:(81)3 3254 2935 FAX:3 3252 8892(<http://www.iwakipumps.jp>)

(J55a^A^ a

B a YW_c : IWAKI EUROPE GmbH	TEL : (49)2154 9254 0	FAX : 2154 1028	U.S.A. : IWAKI WALCHEM Corporation	TEL : (1)508 429 1440	FAX : 508 429 1386
Itz_Y : IWAKI Italia S.R.L.	TEL : (39)02 990 3931	FAX : 02 990 42888	AustraliaY : IWAKI Pumps Australia Pty. Ltd.	TEL : (61)2 9899 2411	FAX : 2 9899 2421
Dzbg_c : IWAKI Pumper A/S	TEL : (45)48 24 2345	FAX : 48 24 2346	Singapi f : IWAKI Singapore Pte. Ltd.	TEL : (65)763 2744	FAX : 763 2372
üj fxg_c : IWAKI Sverige AB	TEL : (46)8 511 72900	FAX : 8 511 72922	IndonesiY : IWAKI Singapore (Indonesia Branch)	TEL : (62)21 690 6607	FAX : 21 690 6612
Fing_c : IWAKI Suomi Oy	TEL : (358)9 2742714	FAX : 9 2742715	Mala'tjY : IWAKIm Sdn. Bhd.	TEL : (60)3 7803 8807	FAX : 3 7803 4800
Norg_c : IWAKI Norge AS	TEL : (47)66 81 16 60	FAX : 66 81 16 61	Taiwan : IWAKI Pumps Taiwan Co., Ltd.	TEL : (886)2 8227 6900	FAX : 2 8227 6818
FrancY : IWAKI France S.A.	TEL : (33)1 69 63 33 70	FAX : 1 64 49 92 73	Tha't_c : IWAKI (Thailand) Co.,Ltd.	TEL : (66)2 320 1303	FAX : 2 322 2477
U.K. : IWAKI PUMPS (UK) LTD	TEL : (44)1743 231363	FAX : 1743 366507	Hong Kong : IWAKI Pumps Co., Ltd.	TEL : (852)2 607 1168	FAX : 2 607 1000
üj Wfg_c : IWAKI (Schweiz) AG	TEL : (41)32 3235024	FAX : 32 3226084	þU : GFTZ IWAKI Engineering & Trading Co., Ltd.	TEL : (86)20 8435 0603	FAX : 20 8435 9181
FU_ci_g_c : IWAKI (Austria) GmbH	TEL : (43)2236 33469	FAX : 2236 33469	þU : IWAKI Pumps Co., Ltd. (Beijing office)	TEL : (86)10 6442 7713	FAX : 10 6442 7712
Holandg_c : IWAKI Holland B.V.	TEL : (31)297 241121	FAX : 297 273902	þU : IWAKI Pumps (Shanghai) Co., Ltd.	TEL : (86)21 6272 7502	FAX : 21 6272 6929
üdB 'g_c : IWAKI Iberica Pumps,S.A.	TEL : (34)943 630030	FAX : 943 628799	: J'dþm : IWAKI Chemical Pumps Philippines, Inc.	TEL : (63)2 888 0245	FAX : 2 843 3096
BelgiY : IWAKI Belgium n.v.	TEL : (32)1430 7007	FAX : 1430 7008	Korea : IWAKI Korea Co.,Ltd.	TEL : (82)2 3474 0523	FAX : 2 3474 0221